

That would be enough

This has been issue 135 of To Win Just Once, published 14th June 2013. It incorporates *Les Petites Bêtes Soyeuses*, a game of *En Garde!*. Issues are published ten times a year, roughly every five weeks. © Paul Evans 2013

Deadlines

Orders for *Railway Rivals* and *Star Trader* to Mike Dommett by 21st June 2013.

Orders for *LPBS* and the *Bonking Game* and any other contributions to Pevans by Friday 28th June 2013.

(Next deadlines: 26th July/2nd August, 30th August/6th Sept, 4th/11th Oct)

Subscriptions

TWJO is published on paper and online at www.pevans.co.uk/TWJO (as a PDF). You can buy or subscribe online or as below.

If you want to play in any (or all) of the games in *TWJO*, you have two options. You can subscribe to the paper edition, which includes the games. Or you can take the PDF edition and pay the “games only” subscription.

This table shows the costs for the paper edition, including postage (& VAT), depending on where you live.

Paper edition	UK	Europe	World
Single issue	£2.85	£4.25	£5.30
1-year subscription (11 issues)	£28.50	£42.50	£53.00

The table on the right shows the games only subscription (including VAT).

Games only	
Per game turn	£0.65
1-year subscription (11 turns)	£6.50

To subscribe, send your name, address and payment to Margam Evans Ltd, 180 Aylsham Drive, Uxbridge UB10 8UF, UK or TWJO@pevans.co.uk. You can pay by bank transfer (to account number 03241742, sort code 09-01-50 or IBAN GB28ABBY09015003241742, BIC ABBYGB2LXXX), by sending a UK cheque or by PayPal to TWJO@pevans.co.uk.

Games played

En Garde! new players are always welcome in *Les Petites Bêtes Soyeuses*. You will need the rules to *En Garde!* in order to play: www.engarde.co.uk

Railway Rivals Anyone for the next game? Working map and rules provided.

Star Trader Anyone for the next one? Rules provided.

Printed and published by Margam Evans Limited
(Registered in England and Wales, number 05152842,

Registered office: 180 Aylsham Drive, Uxbridge UB10 8UF)

Tel: 05601 480486, E-mail: TWJO@pevans.co.uk, Web: www.pevans.co.uk/TWJO

To Win Just Once

(incorporating *Les Petites Bêtes Soyeuses*)



Issue 135: June 2013
(LPBS 263: January 1666)

£2.85 (Europe £4.25, Elsewhere £5.30)
and online at www.pevans.co.uk/TWJO

Contents

Contents..... 2

Chatter..... 3

Letters..... 3

Six Days in Niagara 4

 Pevans reports from the Gathering of Friends 2013..... 4

 About the Gathering 4

Reading Matter 15

Games Events..... 15

Credits..... 16

The Light that Failed 17

Star Trader game 6 – Turn 8..... 17

 Press 18

 Corporation Table 18

 News 18

 Star System Map..... 19

The Bonking Game 20

 Turn 8..... 20

Kingsley Halt 22

Railway Rivals game 9 – Turn 10..... 22

Les Petites Bêtes Soyeuses 263..... 24

 January 1666..... 24

 Press..... 29

 Announcements 29

 Social 29

 Regimental Letters 30

 Personal..... 31

 Poetry Corner 33

 Points Arising..... 33

 Announcements..... 35

 Duels 35

 Tables..... 35

 Other Appointments 35

 Army Organisation and 1666's summer Deployment 36

 Brigade Positions 36

 Frontier Regiments 36

 Battle Results 36

 Regiments 37

 Femmes Fatales 37

 The Greasy Pole 38

That would be enough 40

ID	Name	SL	SPs	Cash	Rank	Regiment/Appointment	MA	Last seen	Club	EC	Player
MC	Sir Monty Carlo	12	36	Withy	B.Lt-General/Cav Div Commandr	10	Charlotte	Hunt	4	Andrew Burgess	
GM	Gaz Moutarde	12	26	Withy	Major RM	3	Anne	Both	2	Mike Dyer	
VV	Sir Voulo Vault	12	F	Comfy	Major RFG/Cds Brigade Maj.	2		Hunt	2	Mark Booth	
BdZ	Sir Bill de Zmerchant	12+	36	OK	Bdr-General/Hvy Brigadier	5		Hunt	3	Tim Macaire	
YVB	Sir Yves Vrai Bretheauteque	11	13	Withy	Colonel DG	5			1	Chris Boote	
PCTW	Pop Goes The Weasel	11	8	OK		3		Hunt	4	G Udowiczenko	
ASli	Armand Slice	10	23	Withy	B.Bdr-General 53F	5	Mary	BG	5	David Williams	
CC	Chopine Camus	10	21	Poor	Colonel GDMD	4	Sheila	BG	4	Stewart Macintyre	
XZ		10	F	OK	Subaltern RFG	6			3	Andrew Kendall	
LL	Lothario Lovelace	10+	30	OK	Captain CG/Capt.C's Esc	5	Josephine	BG	4	Geoff Bowers	
DS	Dexter Siniestre	9	28	Poor	Lt.Colonel GDMD	1	Ava	Hunt	3	Martin Adamson	
TM	Tourtière Mangetout	9	20	Withy	Lt.Colonel 53F/Cav Div Adjutant	3	Sue	BG	4	Howard Bishop	
JA	Jacques As	9+	34	Poor	Major GDMD/Drgn Brigade Maj.	1	Thomasina	BG	4	Joe Farrell	
AS	Arnaud Surfinmaise	8	5	OK		5		BG	5	Nik Luker	
PB2	Pierre Bezukhov II	8+	39	Comfy	Subaltern CG/Trpr.C's Esc	2	Belle	BG	3	Carl Chambers	
FdA	Frele d'Acier	7+	32	Poor	Subaltern GDMD/Bdr's Aide (Drgn)	4	Freda	F&P	3	Peter Farrell	
X3		6	0	OK		2			4	Rohan Keane	
MdA	Marmotte d'Al	6+	20	OK		2	Marie	F&P	2	Neil Packer	
DDA	Dick D'Asterdly	5	10	OK		1			4	Gerry Sutcliffe	
GJ	Georges Jush	5	RIP							Dominic Howlett	
WNM	Was Nae Me	5+	33	Poor	Captain GDMD	5		RP	3	Mark Farrell	
SN	Sebastian Nuisance	4+	14	Poor	Major 27M	4			4	Paul Appleby	
X1		2	0	Poor		4			3	Colin Cowper	
X4		2	F	Poor	Subaltern	3			2	Martin Jennings	

An F under SPs means that the character was at the Front, RIP means that he died. + against SL means it went up this month, - means it went down.

Cash: Poor = <500, OK = 500-1500, Comfy = 1500-5000, Withy = 5000-10000, Rich = 10000-25000, Flthy = 25000+

Last seen is the lady the character was last seen with in public.

EC is Endurance Class: 1 = <60, 2 = 60-90, 3 = 91-120, 4 = 121-159, 5 = 160-200, 6 = 201+

The Greasy Pole

ID	Name	SL	SPs	Cash	Rank	Regiment/Appointment	MA	Last seen	Club	EC	Player
GI	Viscount Gustav Ind	28	54	Rich	Major	CG/State Min.	9		Flr	6	Ashley Casey
GdLi	Count Gar de Lieu	27	71	Withy	General/Justice	Min.	8	Maggie	Flr	4	Bill Hay
DC	Count Devlin Carnate	27	F	Comfy	Colonel	RFG/Min w/o Port	10		Flr	2	Bruno Giordan
EM2	Viscount Egon Mad 2	24	63	Withy	Bdr-General/Min w/o Port		9		Flr	3	Tym Norris
JS	Count Jacques Shitacks	24	59	Flthy	General/Chancellor		3	Madelaine	Flr	4	David Olliver
PC	Earl Pierre Cardigan	23	61	Comfy	Fld Marshal/Min w/o Port		9	Fifi	Flr	4	Matt Shepherd
JdG	Viscount Jacques de Gain	23	47	Rich	B.Bdr-General	KM/3rd Army QMG	17		Flr	4	Ben Brown
EH	Count Euria Humble	22	59	Rich	B.Bdr-General	CG/Min w/o Port	16	Edna	Flr	5	Matthew Wale
TIM	Marquis Tomas le Matelot	21	43	Rich	General/1st Army	Commandr	8		Flr	4	Tim Skinner
QLB	Sir Quasi Le Bossu	18	32	Withy	Lt-General/1st Div	Commandr	9	Guinevere	Flr	6	Mark Cowper
UXB	Marquis Uther Xavier-B'regard	17	37	Withy	B.Bdr-General	PLLD/Drgn Brigadier	9		Both	3	Pete Card
AdL	Sir Armand de Luce	17	F	Withy	Bdr-General		5		Both	2	Francesca Weal
PIS	Baron Pierre le Sang	16	46	Comfy	B.General/2nd Army	Commandr	7	Kathy	Flr	4	Bill Howell
CRV	Sir Charles Rabbit-Vacuum	16	33	Withy	Lt.Colonel	PLLD/2nd Div Adjutant	3	Lucy	Both	5	Mike Dommett
RS	Sir Richard Shapmes	15	39	Comfy	B.Lt-General/2nd Div	Commandr	8	Ella	Both	4	Charles Popp
SYAA	Baron Sheikh Yadiik Al-Abowt	15	27	OK	Major	CG/CPS	5	Katy	Flr	3	Jason Fazackarley
AV	Marquis Ali Vouzon	15	F	Rich	Bdr-General/Gds	Brigadier	7		Both	1	Graeme Morris
AE	Arsène Est	14	43	Poor	Lt.Colonel	CG/FMshl's Aide	6		Both	6	Ray Vahey
EdM	Marquis Eric de Miabeille	14	39	Withy	Colonel	QOC	13	Anna	Both	3	Pete Holland
CMK	Baron Connor McKnight	14	30	Comfy	Bdr-General/2nd Army	QM Gen.	3	Emma	Both	5	Graeme Wilson
WP	Baron Warren Peece	14	30	Rich	Bdr-General/HGds	Brigadier	11		Both	2	Pam Udowiczenko
EB	Sir Etienne Brule	13	30	Comfy	Captain	DG	2	Frances	Both	4	James McReynolds
JIF	Sir Jacques le Franc	13	27	Withy	Major	RM/1 F Brigade Maj.	12	Laura	Both	6	Charles Burrows
ROS	Rick O'Shea	13	25	Comfy	Lt.Colonel	RM/Fntr Div Adjutant	3		Both	6	Paul Wilson
EdSS	Earl Eglise de Sant-Suplice	13	23	Comfy	Major	CPC/Hvy Brigade Maj.	6	Leia	Both	2	Jerry Spencer
Ada	Amant d'Au	13	F	Comfy	Lt.Colonel	RFG	4		Both	5	David Brister
DOG	Baron Donald O'Grady	13	63	Withy	B.Lt-General/Adjutant	Gen	5		Both	3	Bob Bost
MC	Sir Monty Carlo	12	36	Withy	B.Lt-General/Cav	Div Commandr	10	Charlotte	Hunt	4	Andrew Burgess

Chatter

This issue contains the highlights of my trip to the 2013 Gathering of Friends – concentrating on my thoughts about the new (to me) games I played. The full version is on my website. However, this means I haven't had time to complete my report from this year's UK Games Expo. To summarise: I had a good time, the new venue was excellent (with a couple of caveats) and I saw some more new games. Expect my report in next issue.

Meanwhile, I've been suffering with the regression of the weather to Spring. The BBC's weathermen seem to agree with me. On the radio one morning, the forecast for the day was given as "bright and breezy with sunny periods – not bad for March. Shame it's June!" Anyway, I'm sticking with the shorts even if we've still got the heating on (mornings and evenings, anyway).

Now I'm travelling into central London a couple of times a week, I'm getting used to the Tube again. I'm always amused by young women (and it is always **young** women) doing their make-up on the Tube. One jolt, I think, and you'll have your eye out with that eyeliner pencil, mascara brush or whatever. They manage to survive, though.

A recent apparition was a young woman in 8" heels (and three-inch soles – well above what I'd have worn in the days of platform shoes). Having stalked (that's definitely the word – 'tottered' would not do justice to her confidence) into the carriage, she had to wrap her skirt carefully around her thighs and then sit with knees tightly together and feet a yard apart to avoid revealing the colour of her underwear. I hope it was worth the contortions.

TWJO online

The PDF version of last issue shows 96 downloads in May. May adds 58 to the number of times issue 133 has been downloaded, taking it to 195 in two months. Issue 132 has 254 downloads since publication.

Looking at some of the other stats, I was not surprised that most of the new traffic to my site comes from Google. However, in second place is BoardGameGeek – a further indication of BGG's place in the board games community.

Letters

Dominic Howlett has an offer:

I have something like 48 issues of *TWJO* which anyone can have for the cost of picking them up or postage.

Contact Dominic at Dominic_Howlett@newton.co.uk if you're interested.

Six Days in Niagara

Pevans reports from the Gathering of Friends 2013

My transport arrangements to Niagara Falls are getting better. I was only two hours behind schedule arriving this year – much better than the 23 hours of two years ago! As always, flying internationally consists of a tedious progression of queues in various forms, enlivened only by the occasional movie or book. The result is that I was very pleased to arrive at the hotel for this year's Gathering of Friends and get down to the serious business of playing games – and chatting to friends old and new.

I was quickly inveigled into playing *Suburbia* by an old Gathering friend, Steve Lesnik. *Suburbia* is the game Ted Alspach and Bezier Games launched at Spiel '12. It was a sell-out at Spiel and this was the first chance I'd had to play it. Steve and I were joined by *LPBS* player Pete Card and George Michael (no, not that one). As the title suggests, the game is about developing your suburb to a notional city. The most noticeable thing about the game is the triangular central boards and the player's boards with 'bites' taken out of them for hexagonal tiles to fit in. The hexagonal and circular tiles and wooden cubes and cylinders used in the game are much more familiar, in contrast.

Players start with an initial set of hexagonal tiles that represent their town. They will buy additional tiles – from the row of tiles that represents the real estate market – and place them to expand their town. The tiles are coloured to indicate their type with specific details given by the text and icons on the tile (not to mention the illustrations). When placed, tiles may change players' 'income' or

About the Gathering

This year's event was the 24th Gathering of Friends, which started out as a weekend get-together by a bunch of gamers, led by Alan Moon (now well known as the designer of *Airlines*, *Elfenland*, *Ticket to Ride* et al). The following year they did it again, bringing some friends with them. This is the abiding principle of the Gathering of Friends: everybody who comes is a friend (and is invited by Alan). This makes for a very convivial, relaxed atmosphere in which anyone can walk up to anyone and ask to join or start a game. Never mind six degrees of separation; at the Gathering it's hard to find someone more than two degrees away.

Over the years, the Gathering has expanded in time and space: the 2013 event had 370 attendees over nine full days (though not everybody was there for the whole time). It has moved, too, arriving in Niagara Falls in 2011 after several years in Columbus, Ohio. There is an increasing business element to the Gathering, as well. Games designers bring prototypes to test and show to the publishers who attend. However, the emphasis remains on playing games and having fun. The event would be recognisable to anyone who's attended any gamer-organised convention in the UK. It consists of people playing games – most of which they've brought with them and made available to everyone else. I always have a good time.

Femmes Fatales

No	Name	SL	Attr	Last
64	Edna Bucquette	18	W	EH
3	Kathy Pacific	17	B	PIS
54	Madelaine de Proust	17		JS
35	Katy Did	16	I	SYAA
42	Maggie Nifisent	16	B	GdLi
55	Jacky Tinne	16		

Regiments	RFG	CG	KM	DG	OOCALC	CPC	RM	GDM	PM	13F	PLLD	53F	27M	4A	69A	Gscn
	Col	EH	JdG	YVB	EdM	N4	N2		CC	N6	AV	UXB+ASII	N5			
LCol	AdA	AE	N3				ROS	DS	N5	CRV	TM	N5				N3
Maj	N4	GI	N3	N5+	N6*	Edss+GM	N3+	N3	N3	N4	N4+	SN	N1+	N1+		
Maj	VV+	SYAA					JIF+	JA+		N3						
Capt	N5	LL	N6	N4	N4	N5	N2	N5	N2	N6	N2	N4	N1	N6	N4	N4
Capt	N2		N5	N2	N4	N2	N1	N2	N4	N1	N4	N4	N2	N3	N5	N6
Capt			N5	N3	N5	N3	N4	N4	N4	N4	N2	N1	N2	N6	N3	N6
Capt			N5*	N2*	N5*	N3	N6*	N1*	N4*	N6*	N6*	N6*	N5*	N5*	N1*	N1*
Capt																
Capt																
Capt																

This table shows the ten senior positions in the 17 regiments by rank. Entries are Character abbreviations, N (+MA) for NPCs, blank for vacant. * shows the regiment adjutant; + shows ranks held by characters with a (senior) brevet rank or an appointment elsewhere.

No	Name	SL	Attr	Last
52	Guinevere d'Arthur	15	B/W	QLB
10	Frances Forrin	14	B	EB
21	Helen Highwater	14	W	
48	Fifi	14	B/W	PC
62	Alison Wunderlandt	14		
11	Laura de Land	13		JIF
16	Ophelia Derriere	13		
26	Ella Fant	13	B	RS
27	Lucy Fur	13	B	CRV
30	Leia Orgasma	13	B	EdSS
45	Cath de Thousands	13		
8	Lotte Bottle	12	B	
12	Charlotte de Gaulle	12		MC
17	Henrietta Carrotte	12	I/W	
28	Vera Cruz	12		
31	Bess Ottede	12	I/W	
1	Sue Briquet	11	B	TM
4	Anne Tique	11	W	GM
9	Deb Onairre	11	I	
40	Sheila Kiwi	11		CC
63	Carole Singeurs	11		
20	Emma Roides	10	I	CMK
33	Anna Rexique	10	I	EdM
38	Pet Ulante	10	W	
43	Di Lemmere	10	I	
53	Angelina de Griz	10	B	
56	Ingrid la Suede	10		
6	Viv Ayschus	9		
57	Ava Crisp	9	I	DS
59	May Banquot l'Idee	9		
2	Betty Kant	8	I	
19	Jenny Russe	8	W	
32	Sal Munella	8	W	
41	Marie Antoinette	8	B/I	MdA
49	Mary Huana	8	B/I/W	ASli
34	Freda de Ath	7	W	FdA
39	Thomasina Tancenjin	7	I	JA
50	Ulla Leight	7	I	
5	Belle Epoque	6	B/I	PB2
13	Josephine Buonoparte	6	I/W	LL
24	Violet Bott	6	I/W	
15	Ada Andabettoir	5	B/I	
25	Lois de Low	5	B	

This table shows the mistresses in Paris. B = Beautiful, I = Influential, W = Wealthy; Last = Last lover seen with this month

Army Organisation and 1666's summer Deployment

First Army (Defence)	TIM/__/N3/N
Guards Brigade (Defence) - RFG CG KM	
Second Army (Assault)	PIS/__/N5/CMK
First Division (Assault)	QLB/N/__/
1st Foot Brigade (Assault) - RM PM	
2nd Foot Brigade (Assault) - 13F 53F	
Second Division (Assault)	RS/N/CRV
3rd Foot Brigade (Assault) - 27M 4A	
4th Foot Brigade (Assault) - 69A Gscn	
Frontier Division (Assault)	N4/N/ROS
Frontier Regiments (Assault)	
Third Army (Field Ops)	N1/N/N5/JdG
Cavalry Division (Field Ops)	MC/N/TM
Horse Guards Brigade (Field Ops) - DG QOC	
Heavy Brigade (Field Ops) - ALC CPC	
Dragoon Brigade (Field Ops) - GDMD PLLD	

Organisation and Deployment for the Campaign Season with Army and Division posts (Commander/Aide/Adjutant/QMG)
 Entries are ID for player characters, N (+MA if needed) for NPC, __ for vacant

Brigade Positions

Guards Brigade	AV/N/VV	First Foot Brigade	__/__/JIF
Horse Guards Brigade	WP/N/N5	Second Foot Brigade	N2/N/N4
Heavy Brigade	BdZ/__/EdSS	Third Foot Brigade	N6/N/N1
Dragoon Brigade	UXB/FdA/JA	Fourth Foot Brigade	__/__/N1

Current CO/Aide/Brigade Major of each Brigade; entries as Army table

Frontier Regiments

	(Siege for Dec-Feb)				
Colonel	F1	F2	F3	F4	RNHB
	N6	N3	N1	N4	N4
Attached		AdL	X4		
Also at the Front	Guards Brigade (Royal Foot Guards)				

This table shows the Colonels of the Frontier regiments (N+MA for NPCs), together with the volunteers assigned for the season.

Battle Results

Guards Brigade: 1	Frontier regiment 3: 5
Royal Foot Guards: 1	Frontier regiment 4: 2
Frontier regiment 1: 3	RNHB regiment: 3
Frontier regiment 2: 3	



Suburbia on display at Spiel '12 (photo by Mike Dommett)

'Reputation' (tracks on the players' boards) according to both what they do and how they interact with other tiles – a clever touch. Both of these affect player's 'Population', which is shown on the scoring track because Population is how you win the game!

On first acquaintance, I found *Suburbia* fascinating with some interesting twists on familiar mechanisms. It's a game where you have to balance what you're doing to get the best from your position. The group I played with felt that the game is a multi-player solitaire. That is, each participant plays their own game with no interaction with the others. I have no problem with this kind of game and I give it a provisional 8/10 on my highly subjective scale. The best news is that a second edition is on its way.

An early night was required on my first day at the Gathering, but I was up bright and early to start on some more games the following day. First, however, I was co-opted to explain the rules to *Keyflower* for a group of new players. With that



Completing the set-up of our game of *Terra Mystica*

out of the way, I could get on with playing something. In this case, *Terra Mystica*, which I know is a lot of people's favourite of last year. I'd carefully avoided reading any reviews, though, and had somehow gained the impression that it was a card game. Boy was I wrong! Pete Card and I were joined by Nick Ramsey and Maryl Fischer for our introduction.

Terra Mystica is a complex, strategy board game, which I will now summarise ... No, I give up! There is an awful lot going on in this game. In a distinct contrast to *Suburbia*, which has pretty simple rules, *Terra Mystica's* rules are complicated. At the core, though, each player needs to get more of their buildings onto the board. Each building increases players' income – not just in cash, but also workers, priests and magical power. The players are different fantasy races (dwarves, halflings et al) and each can only build in a particular terrain (forests, marshes, mountains and so on). However, they have to build next to their existing buildings, so must convert spaces to the right terrain.

That gives you a taste of the game. On top of this, players can improve their actions – or make them cheaper – by spending resources. Hence one decision each round is whether to spend resources on doing things now or use them to improve actions so that you can do more in subsequent rounds. There are only a limited number of rounds, so there's time pressure as well. And bonus points are available each round, giving players an incentive for specific actions that round.

Terra Mystica is a game that has to be played in order to get to grips with, but it's appealing enough that it's fun the first time you play. It's a clever,

Announcements

Eglise de Sant-Suplice asks NPC Colonel of Crown Prince Cuirassiers to resign

Duels

Results of January's duels:

Arsène Est (with PC, gains 1 Exp) beat Donald O'Grady (with EB & UXB).

Eglise de Sant-Suplice declined to meet Euria Humble as he was under half Endurance.

Sheikh Yadik Al-Abowt (with PB2, gains 1 Exp) beat his enemy Eglise de Sant-Suplice.

Eric de Miabeille (gains 1 Exp) beat his enemy Etienne Brule (with DOG).

Sheikh Yadik Al-Abowt didn't turn up to fight Rick O'Shea and lost SPs - voted cause 12:2.

Grudges to be settled next month:

Sebastian Nuisance (Rapier, adv.) and Was Nae Me (Sabre, Seconds DS, 3 rests) have mutual cause as neither stood down over Ada.

Tables

Other Appointments

King's Escort: Ensign N	Captain N
Cardinal's Escort: Ensign N	Captain LL
Aides: to Crown Prince N	to Field Marshal AE
Provincial Military Governors: N/N/N/N/N	
City Military Governor N	Adjutant-General DOG
Inspectors-General: of Cavalry N	of Infantry N
Commissioner of Public Safety SYAA	
Chancellor of the Exchequer JS	Minister of Justice GdLi
Minister of War N	Minister of State GI

Shows who holds appointments outside military units:

ID for Characters, N for NPC, __ for vacant,
CPS for additional posts held by the CPS.

Arsène Est (Sabre, Seconds PB2 & PC, adv.) and Donald O'Grady (2-Hand, Seconds EB & UXB) have mutual cause as neither stood down over Jacky.

Etienne Brule (Rapier, Seconds DOG, 1 rests) and Eric de Miabeille (Sabre, adv.) have mutual cause for being in enemy regiments.

Tomas le Matelot (Sabre, Seconds PC & PIS, adv.) has cause with Arsène Est (Sabre, Seconds PB2 & PC, 4 rests) for pinching Jacky.

"adv." shows who (if anyone) has the advantage in Expertise: his first duelling sequence need only contain six Actions.

All duels (including any to be voted on) must be fought next month unless held over due to one or other duellist being at the Front. Orders conditional on a challenge being voted cause are acceptable.

Absent friends

The following didn't get their orders in on time ("No Move Received") and suffered the consequences.

TIM Tomas le Matelot (Tim Skinner) has NMR'd. Total now 1.

AS (Nik Luker) has been floated due to "chaotic life"!

PGTW (Gerald Udowiczenko) and WP (Pam Udowiczenko) were floated as both are "drowning in work".

X1 (Colin Cowper) was floated, but Colin is now back online and expects to be with us again next month.

X3 (Rohan Keane) got the benefit of the doubt and was floated.

YVB (Chris Boote) was floated as Chris is in the Netherlands.

Farewell

This turn we say goodbye to Dominic Howlett (currently GJ), who's finding that he doesn't have time for the game at the moment. Thanks for all your input to the game, Dominic, and you are very welcome to re-join us any time in the future.

Three Sails Trading Co

As noted in passing in the report, the good ship "Fair Wind", chartered by the company, is reported (by other ships who have now returned to France) to have arrived safely in the Caribbean. The ship is presumably carrying out its trading mission and avoiding pirates and then just has to re-cross the Atlantic safely...

Fleur bonds

The estate of the late Count Zachary The Money Goes is pleased to make a number of bonds in the Fleur de Lys club available to buyers. The bonds have a nominal value of 1,000 crowns and provide the owner with a share in the club's profits (paid quarterly). Offers in the region of 1,500 crowns should be made to the offices of Sue, Grabbit and Run, lawyers.

Notes

The *En Garde!* rules are available to LPBS players at a reduced rate: see any month's Points Arising web page at www.pevans.co.uk/LPBS; or send a cheque (payable to Margam Evans Limited) for £8.40 (inc postage to UK addresses) to LPBS, 180 Aylsham Drive, Uxbridge UB10 8UF.

There's a Yahoo! group for *En Garde!* players that provides a forum for players of different games to swap stories and ideas. Sign up and get talking at: <http://games.groups.yahoo.com/group/EnGardePlayers/>

Reminders: It is worth sending orders in even if they're a day or two late: I may be able to action the orders and should be able to use any press. It also reassures me you're still there.

Orders (and press) should be e-mailed to lpbsorders@pevans.co.uk – you'll get an automated reply when your message arrives in my mailbox. Please give your name and your character's name and specify actions in full (since it's without your character sheet). If you want queries answered before the deadline, e-mail LPBS@pevans.co.uk instead.

challenging game and I can see why so many gamers like it. I enjoyed the game (and have played it again since) and give it a provisional 7/10 on my highly subjective scale.

One of the discoveries of this year's Gathering was The Culinary Institute, one block along the road at the side of the hotel. As part of its students' training, the Institute runs a sandwich bar, a coffee shop and a fine restaurant (not to mention a wine merchant!). It quickly became a regular attraction for Gathering attendees, for both lunch and dinner.

So, after a substantial lunch, it was back for another game. The game was *Bora Bora*, the latest from Stefan Feld and alea. My first thought was: colourful! The board shows a group of islands, each split into several areas, as is the sea between them. Players get to place their wooden 'huts' on the islands, pushing to one side any other player's piece that's already there. This is a neat mechanism as players want to get the most out of placing huts by doing so early on. However, they will only get the bonus for occupying areas at the end of the game if they're the last to arrive.

That's just one of the things players can do, though. The actions available, including adding a new hut, are shown on the board. At the start of a round, players roll their dice. To take an action, players place a die on the action space. Generally, the more spots on the die, the more of that action the player can do. However, they can only place a die if it has fewer spots than any of the dice already on the space. Another neat mechanism! It also means that all values on the dice can be useful – ideally you want to roll a mixture of high and low values.

The game is just like this: packed full of clever tactical options that give players a lot to think about each round. One thing that you may not appreciate the first time you play is that the very useful end-of-game bonuses are tough. As the game



I told you it was colourful! Bora Bora in play

has a set number of rounds, you need to commit to these on round one to have a good chance of getting them. *Bora Bora* is an ingenious game and not too hard on the grey matter: I give it a provisional 8/10 on my highly subjective scale.

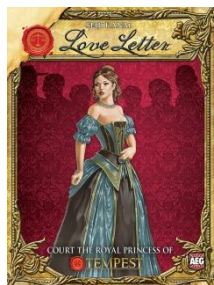

Wednesday started with *Love Letter* (designed by Seiji Kanai) and I am indebted to Brian Bankler for introducing me to this gem. This is a beautifully crafted little game: just 16 cards – and only eight different ones. Players start with one card each. They draw one and play one, taking the action shown on the card, until the deck runs out. The aim is to have played the highest total of card values in the round – but you can get knocked out of the round! The other cards' actions offer hints as to who's holding what card, which influences what you play. The first player to win a set number of rounds wins the game.

This is such an elegant game. It's as if someone has taken a deck of cards and whittled it down to just the minimum necessary. Or perhaps a haiku is a better analogy – profundity in seventeen syllables (appropriate, given the Japanese designer). Just playing a few hands it was clear that there is some subtlety to the game and I could see people's tactics evolving as they learned. The AEG version, which we were playing, looks absolutely gorgeous as well. It's a cracking little game and gets a provisional 9/10 on my highly subjective scale.



The end of the first round in *Triassic Terror* – note the large dinosaurs on the right where action tiles have been taken from

for his execution, the fellow began blubbing for his life and offered to provide me with 'some names' of others that he knew were also witches and involved in the dark arts, if only I would spare him. Most pitiful really. Of course, I am merely a servant of the Crown, committed to undertaking the orders delivered to me and it is not within my power to overturn the sentence of the court.

Alas, I feel this may not have come across particularly clearly to Bartat as he seemed to take heart somewhat when, just prior to his execution, I sat him in a chair in my office, provided him with a glass of wine, some fine cheeses and ham and gave him several sheets of paper and a quill so that he could fully detail what facts he believed to be of use to the Ministry. The look upon the poor fellow's face when, having finished his writings, he was told that the firing squad was now waiting for him and that the bonfire was at just about the right heat was a picture to behold!

However, the names provided by Bartat prove that the tendrils of evil have spread further than first thought and I must act before this escalates beyond control. The witches must be purged through fire, as I am sure you will wholeheartedly agree. My staff have been instructed to

Points Arising

Next deadline is 28th June

The terms of office of the current Commissioner of Public Safety (SYAA) and Minister of War (an NPC) run out at the end of next

commence immediate investigations and surveillance into this latest threat. The Ministry will keep you updated as to developments. If anyone has evidence or suspicions relating to any individual who may be involved in this foul practice, please contact me as a matter of urgency (discretion assured).

† Baron Sheikh Yadik Al-Abowt
Commissioner for Public Safety

Lord Percy Percy affirms his continued loyalty to His Majesty and states he is not whatever that weird guy said he was.

Poetry Corner

(All signed poetry submissions gain their author at least 1 SP)

The man was magnificent and brave,
The lady was pretty and suave,
But the child was pure excrement –
We know him as de Zmerchant –
We hope he dies at the front.

† Was Nae Me, Captain GDMD

Found scratched in a whitewashed
privvy behind the Fleur:

Row, row, row your boat, gently down
the Seine.

If you see the CPS, don't forget to
scream...

† The Privvy Poet

month. Anyone wishing to apply for either (or both) of these appointments should do so with their February orders (and this will be resolved at the beginning of March).

As announced last month, I am off on my travels... as a good Rogue & Vagabond should – but I hope my friends in the Boozers & Bellringers had a suitably well-oiled AGM.

† AdL

To: The Management Committee of the Boozers and Bellringers

I am aware of the special meeting being called by the Chairman to discuss the issue of my membership of this organisation. Let me say that I am a little surprised that the matter of my membership is under discussion simply because I helped rid the country of two despicable criminals. The law must always be followed and justice pursued in the event of foul play. My volumes of law and committee constitutions show no valid legal grounds for the removal of a member as per this scenario and I must therefore urge you to consider your actions with caution...

† Baron Sheikh Yadik Al-Abowt, CPS

To SYAA

From QLB

The B&B board has voted for you to be banned for life for causing the death of ILB. The fallen women of Montmartre are really upset and, believe me, you don't want to upset these ladies. The sewing club have great plans for you, I'm told. I suggest you avoid the area.

Overheard at a senior commanders' meeting of the Cardinal's Guard.

"May I press you to a vol-e-vont?"

"Bit messy."

To SYAA,

This is just a polite note to assure you that, even if His Eminence the Cardinal had not forbidden it, I would not be attempting to return the late ILB to life.

I have taken the opportunity to compare the result of his trial, amongst others, with that of my new scientific method of determining the likelihood of someone being a traitor and I am pleased to say that my "Treasonometry" (as I call it) produces the same result in every case. Should you require any more information please do not hesitate to contact me.

† Viscount Madd

Le Canard Enchaîne

All Paris is quaking with the rumour that Madame Guillotine has been seen on Le Place de la Concord. The brutal slaughter of Baron ILB, an innocent and upright servant of His Majesty, shows that no-one is safe. Only two months before, the CPS was begging to be made a member of the Royal Marines, now he fabricates evidence against one of Paris' finest. So, gentlemen of Paris, beware when the Sheikh offers a hand of friendship: you are next for the chop! To be continued...

To: The Gentlemen and good people of Paris

Rejoice that the menace of the lately executed villain Ilk Lamore Bartat has been removed. Bartat was a monster, but one that the state was able to break. It may interest you to know that, following his trial, when I was escorting him back to the Bastille

Who can say no to a game that involves stomping about the board with dinosaurs? No, me neither. I joined two old gaming buddies, Chris Kovac and Steffan O'Sullivan, and a new one, Paul Dupuis, to play *Triassic Terror*. This is Peter Hawes's game from Kayal Games, a new publisher to me. The board is divided into areas of different terrain, each with three levels. Players marshal their herds of little wooden dinosaurs around these twelve regions.

The stomping is done by the large, plastic Tyrannosaurus Rex and raptors, who dispose of smaller dinosaurs. Moving these is done by the players as part of one of the several actions available to them. The actions are denoted by a row of cardboard tiles and players take the tile for the action they want each round. Actions let them move their dinosaurs, add new dinos and so on. Crucially, only one player gets each action in a round, so choosing the right one is key.

Triassic Terror is a fairly lightweight, fun game with some neat tactical options and a clever scoring mechanism. It's played over a set number of rounds with a few scoring rounds mixed in. You could approach this game with your thinking cap on, but I treated it as a romp and had good fun. It gets a provisional 7/10 on my highly subjective scale.

Meeting up with a couple more old friends, Joe Huber and Michael Tsuk, I was given a choice of types of game to play. I opted for pick up and deliver, a kind of game I enjoy a lot (all the way back to *Auf Achse*). Joe promptly produced *The Great Heartland Hauling Co*. This is an ingenious little card game from Dice Hate Me Games (produced as a Kickstarter project and designed by Jason Kotarski).

To start the game, a number of 'Location' cards are laid out to provide a network connected by roads. Each location shows the goods it produces – cubes are placed for these – and those it will buy. Players move their good-looking trucks between locations using fuel cards from their hand (or cash if the cards run out) to pick up cubes and deliver them where there's a profit. However, they have to have the corresponding goods cards in hand both to pick up and to deliver.

Apart from the question of how best to get from A to B, players must also wrestle with the limits of what their truck will hold and how many goods each location will buy. There are some neat wrinkles to the game, but it's not particularly demanding. I had good fun playing it – though this may have been the company I was with, as they were both in fine form! *The Great Heartland Hauling Co* gets a provisional 8/10 on my highly subjective scale.



Playing *The Great Heartland Hauling Co* – note that we've each stood our truck on a different side so that we can tell them apart. Ahem.

I'd been looking for the chance to try Peter Hawes's very latest game and a fine-looking pre-production copy of *Francis Drake* was sitting on a table not far from where I'd just finished playing. I seized the opportunity now. The game is played on a big board, the main part of which is a map of the Caribbean, divided into areas according to how far they are from England and showing the town, forts and galleons that are the players' targets.

The rest of the board is a track that represents Plymouth harbour, where players outfit their ships for each expedition. This is a neat mechanism where players must choose how they want to equip their ship: how many guns, how big a crew, what trade goods? They key is that you can't move back along the rack. So do you jump forward to get what you want or lag behind and only get the scraps? To provide variety, the printed track is replaced with tiles dealt at random in subsequent rounds.

Francis Drake is played over three voyages. Players equip their ships, hit their targets in the Caribbean – unless someone else gets there first – and return with their plunder. As we discovered, players really need to plan their expeditions from the off, deciding which targets to go for in what order. We had a lot of fun playing this and the result was a very close game. *Francis Drake* gets a provisional 8/10 on my highly subjective scale and I look forward to playing it some more when it's published. (Expect it this autumn from Eagle Games.)



The *Francis Drake* board with the Plymouth track at the top

De ZMerchant, your insult to the Regiment will be remembered, even though your injuries excuse you from having to defend your words.

† C R-V

To Lt.General Sir Monty Carlo

I note from last month's press that you refused my Colonel entrance to a religious meeting, due to the impression you seem to have that he is not a gentleman. Colonel Camus commands one of His Majesty's regiments and His Majesty would surely not allow a non-gentleman to command any of his regiments, or are you questioning His Majesty's judgement in these matters! The CPS has investigated people for less.

Your hatred of Colonel Camus and the Grand Duke Max's Dragoons is obvious, given the repeated embarrassments that you and your lackey d'Zmerchant suffered on the duelling fields. So much embarrassment that you both had to volunteer for the front, out of season, to avoid further engagements.

For a soldier of your rank to have such petty and puerile feelings towards your subordinates is unfitting and, dare I say, ungentleman like.

I await your apology to Colonel Camus.

† Major As, GDMD

Lt General Delmonte Carlo

I see that pillaging Normandy of fruit for your cider venture has allowed you and your lackey, Bill d'Zmerchant, to work your way into the General Staff. Whoever heard of

being promoted for patrolling the countryside during peacetime? How do you find loot on patrol in your own country? I can answer that now I have heard reports of 300 Crowns extorted from the peasantry! And you call yourself a gentleman? I think Paris needs to know what sort of men you really are!

I am writing to you to demand satisfaction for the slurs to Colonel Camus, who was not allowed entry to your Minor Saint Society. On the account of, according to you, GDMD are not gentlemen.

In the summer campaign fighting at the front fine members of the GDMD died defending France. Your comments besmirch their honour, and that of the armies of France. Be prepared to back them up with steel.

† Subaltern d'Acier

Personal

To my friends in Paris, Apologies for suddenly vanishing from Paris and our happy social lives. I have been called away on family business which has consumed all my time and energy for several weeks. Please take care, my friends, and know that I miss you.

Yours etc, † WP

Lord Percy Percy says, as over-large is strangely fashionable, Jacques Shitacks has very fashionable meal portions.

In what way does a Cathar Bible differ from the true bible, written in Latin of course?

† Le Moulin Blanc

Dear Paris,
We have recently seen some terrible atrocities, acts of treason, bestiality, witchcraft and acts of such extreme indecency that at times we might mistakenly think that we are English! Well we are not, we are French under God and King and I say it's time to bring out that great bastion of goodness – the cheese wheel!

I will be hosting a month long party in February at my club to chase away the darkness we are under.
Weeks 1 to 4 – all above SL 21
Week 2 – all above SL 18
All costs at my expense, Mistresses expected.

Yours in wine and cheese,
† General and Chancellor Shitacks

Pierre Cardigan will be hosting a party all month: SL17+ welcome.

Due to the recent discovery of Cathar heresy amongst even the officer ranks of our most Catholic Majesty – King Pevans (God Bless Him!) I have decided to hold a month-long prayer meeting and Bible recital in a specially sanctified cellar of the Fleur. All the gentleman of Paris are invited to attend, Mistresses may also attend but must be suitably attired so as not to inflame the unholy lust of those gathered. No costs will be paid, and gambling will not be tolerated. Let us hope that with our prayers and Gods help this wicked sect can be banished back to the hell which spawned it.

† Count Euriah (Ever So) Humble.

I wish to announce a dinner party to the gentlemen of Paris and their ladies: to take place during Week 4 of February, 1666, at the Fleur de Lys. All gentlemen of the better sort (SL 10+) and their ladies are invited to dine and carouse at my expense. Also invited are the serving officers and other ranks of the 53rd Foot and their ladies (regardless of SL).

† General Pierre le Sang

To all members of B&B
We will hold a wake to celebrate the life and times of our fallen comrade, Ilk Le Bartat, in the Fleur de Lys in Week 1 of February 1666. All members welcome to attend with their mistresses. All costs will be met from club funds. Anyone who looks like a Turk, wears a turban or arrives riding a camel will be refused entry.

† Chairman Quasi Le Bossu

Regimental Letters

To Bill,
Is that Sir Bill – or Bill the Cur?
(that's a sibilant C for you Cuirassier lackwits.)

Yours, † Dex

Bill de Zmerchant,
The GDMD have had a whip round to get you a little something as a result of your promotion from the ALC. As a token of the esteem that they have for you, I offer you a dead rat. Do not feel too disappointed, as several promissory notes to fund you on a Royal Carribean Cruise as a slave to the plantations were also included.

† Was Nae Me, Captain GDMD



Starting the *Clash of Cultures* – look at all that unexplored land!

Friday began with a game I really wanted to play: *Clash of Cultures* from Z-Man Games (designed by Christian Marcussen). I'm a sucker for civilisation development/expansion games and joined some old friends, Ralph Anderson and Leo Tischer, to try this out. Each player starts with the beginnings of a city in a small territory. Between them lies unexplored land. As you'd expect, the players explore, build and, perhaps, fight.

Two things really make the game. The first is the technology development. Each player has a separate board to track their technology in a dozen different areas. Each of these provides players with advantages (and some disadvantages) that help them develop their 'culture' in particular directions. The other thing is the terrific playing pieces. I particularly like the buildings that fit together so that a full set makes a complete city.

All the different technologies make this a complicated game, though it's surprisingly easy to pick up on your first playing. All in all, *Clash of Cultures* is an excellent empire development game with some really clever touches. Our game had limited conflict, but lots of development. I'm smitten: it gets a provisional 8/10 on my highly subjective scale.

After a complicated game, it must be time for something simple. Steffan O'Sullivan recruited me to learn *Cinque Terre* (designed by Chris Handy,



Cinque Terre set up and ready to go

published by Rio Grande) with him. This is a brightly coloured, simple game of delivering fruit and veg on the Italian Riviera. No, really!

Key to the game are the wooden models of the motorised carts that transport your goods. The game rules tell you to put the cubes on your board, but they fit nicely on the backs of the carts. So that's what we did! The heart of the game is actually the cards that show orders for a particular mix of goods to be delivered to specific villages. In addition, players can sell goods that correspond to the coloured dice set out at the villages.

Game play is quite quick as there's only one thing to do each round. Despite its lightness, there's more to this game than initially meets the eye – I should certainly have taken it more seriously! It's an excellent filler for gamers and a fine family game. It gets a provisional 7/10 on my highly subjective scale.

Friday evening saw me – and several others – battle against a fierce wind to get a couple of hundred yards down the road and dine at the Culinary Institute. The food was excellent, as was the company. One thing I didn't expect was that the restaurant would serve a range of locally-brewed beers. Not only that, but they offered a tasting selection so that I could try them all. Excellent stuff.

for Armand Slice (sabre), Frele d'Acier (sabre), Dick D'Asterdly (rapier), Egon Mad 2 (rapier), Gaz Moutarde (cutlass), Jacques As (sabre), Monty Carlo (two-hander), Pierre le Sang (rapier), Rick O'Shea (cutlass), Richard Shapmes (rapier) and Tourtière Mangetout (rapier).

A flurry of visitors to the Bawdyhouses (Egon Mad 2, Dexter Sinistre – a man who doesn't need female company, apparently – and Was Nae Me) gets the attention of the local footpads. They strike the following week, targeting Rick O'Shea and Sebastian Nuisance. Both men have spent all their cash on wine and women, though. Bill de Zmerchant escapes the muggers' attention – just as he wasn't noticed when he went courting earlier – even though he re-scheduled his debts this month. Dick D'Asterdly is the last visitor to the Bawdyhouses, so the footpads jump on him enthusiastically. He has no money left either.

Victory in the Pyrenees

The Royal Foot Guards and Guards Brigade HQ take up their positions in the foothills of the Pyrenees. They find some advanced Spanish positions and quickly starve out the occupants. Colonel Devlin Carnate refuses the promotion he is offered, but accepts the 1,400 crowns of booty his personal bravery brings him. Lt-Colonel Amant d'Au goes a hundred crowns better with his share of the loot: 1,500 crowns worth. The regiment's latest recruit, Private 'X2', gains promotion to Subaltern and adds a round thousand crowns to his assets. This is all good news for Brigadier Ali Vouzon. He dips into the plunder pool to take 1,400 crowns for himself and receives the title of Marquis. Brigade Major Voulo Vault takes 700 crowns for his allocation. He writes up the Despatches, in which he is Mentioned.

Brigadier-General Armand de Luce is serving with Frontier regiment 2. His advice to the regimental commander brings him a Mention in Despatches. 400 crowns worth of loot comes his way as well. 'X4' has also volunteered for death or glory. Death almost finds him when a musketball hits him. Luckily, the round is almost spent and it just lodges in his tunic. He is promoted to Subaltern. ❖

Press

Announcements

The Dragoon Brigade **will** be visiting the front in February. Glory awaits some, death for others. Vive le Roi!

QOC welcomes new recruits. Financial assistance available on request.

† Marquis Eric De Miabeille
Colonel

Social

February 14th (Week Two) sees the feast of St. Cyril and Methodius. All gentlemen and their ladies are welcome to this meeting of the Minor Saints' Society at Hunter's, as we celebrate the lives of those who took Christianity to our brothers in Russia. † Sir Monty Carlo

The main event of week 4 is in Bothwell's, where Etienne Brule hosts his Cavalry Officers' Luncheon with Frances. Interestingly, the first guest is not a cavalryman: Armand Slice, commander of the 53rd Fusiliers, with his companion, Mary Huana. His subject for after-dinner debate is "gold braid – just how much can you wear without looking a complete git?" There's an uncomfortable silence before the assembly bursts into laughter. As Brigadier of the Heavy Brigade, Bill de Zmerchant wears plenty of gold braid, but he gets the joke. The subject he offers is more serious: "Heavy Cavalry Tactics: Charge or Impetuous Charge?"

GDMD Lt-Colonel Dexter Sinistre brings Ava again and a sheaf of discussion suggestions: "Is the lance a future cavalry weapon – or is it only good for pig sticking?"; "Are two-handed swords a cavalry gentleman's weapon or are they something that should be banned?" and "Are the Archduke Lobster Cuirassiers a waste of good skin?" His colleague, Frele d'Acier, escorts Freda once more. He suggests their host should invite Monty Carlo to explain how an oaf with a fruit peeler fetish reached the General Staff. This meets with much approval as well.

Jacques As is another member of the Grand Duke Max's Dragoons, but on secondment to the Dragoon Brigade. He brings Thomasina and offers a more serious topic: "Should gentlemen lower themselves to use a double handed sword?" Sheikh Yadiq Al-Abowt is not a cavalryman, but he is Commissioner of Public Safety. Katy Did accompanies him. And last man in is Was Nae Me, making the most of his first month in Paris. He has a suggestion, too: "Bareback or in the saddle, which gives a better ride?" While he was initially struck with Bill's topic, Etienne gives the prize to Armand for his witty suggestion.

The only other member in Bothwell's is Connor McKnight: his fourth visit with Emma. They would have been the only people in the club in week 3 had not Richard Shapmes and Ella Fant been there for the second time this month. Blue Gables sees Tourtière Mangetout visit in week 3 with Mlle Sue Briquet, while Pierre Bezukhov II and Belle are there at the end of January. And Marmotte d'Ai and Marie are in the Frog and Peach for the latter half of the month.

Arsène Est's month concludes on a high note when his courting finally pays off. Tomas le Matelot will not be so happy, though. The iron man title is shared this month between Gustav Ind and Jacques de Gain, who practise rapier all four weeks. Chopine Camus puts in three weeks with his sabre, as do Charles Rabbit-Vacuum, Eric de Miabeille and Pierre Cardigan. Eglise de Sant-Suplice is to be found practising rapier for three weeks and it's cutlass for Marine Jacques le Franc. There's a fortnight's practice



I finished Friday with something rather more demanding: Portal Games's co-operative *Robinson Crusoe* (designed by Ignacy Trzewiczek). Having played before, Kris Gould did the honours and led a team of first-time shipwreckees (if that's a word – spellcheck says "No") onto the shores of the traditional desert island. Though it's probably more of a mysterious tropical island – without any sign of polar bears, luckily.

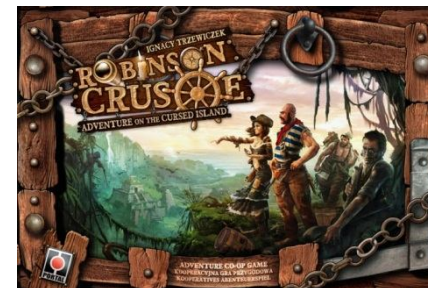

The large board is only partly taken up with a map – which starts blank except for the beach on which the players have just washed up. This is not all bad news as the beach does provide some food. However, the necessities of life take over. You need water, food and shelter. And food has this habit of running out (harvested all those bananas?) or going bad. You realise how necessary shelter is the first time a storm hits the island!

The rest of the board has spaces for the different hazards that face the players (wild animals, for one) and the various things they may be able to make to help them: a lantern, maybe, or a shovel... Each player also has a board to show the specifics of what is happening to their character and what they can do.

Each round starts with, in effect, a team meeting where the players decide who's going to do what that day. This is a brilliant way of handling a co-operative game



Playing *Robinson Crusoe* – we've explored a bit of the island

and allows the players to take into account their different strengths as well as the urgencies of each day. You'd always like to send the team's best explorer to explore. However, if they're sick, they need to spend the day in the camp and someone else will have to go exploring.

Robinson Crusoe is a tough and highly atmospheric game. There's a real sense of a narrative running through the game, focused on the issues confronting the shipwrecked players. What's more, the game provides several different scenarios. We were playing the basic scenario where all we had to do was survive, but the others put additional pressures on the players. It's absolutely brilliant and a demanding challenge: it gets a provisional 9/10 on my highly subjective scale.

One of the regular events at the Gathering is that James and Sheila Davis organise an 'Overlord' game of *Memoir 44*. Overlord uses two boards in a row with three battlefield Generals plus a commander-in-chief for each side. I managed to squeeze into this year's game on Saturday morning. I had some success against my opposite number, Sheila, but the result was a (narrow!) win for the Axis as they held on to the town that was the main objective. Good fun was had by all – thanks to my teammates and opponents.

The climax of the Gathering is the prize ceremony late on Saturday afternoon. Alan Moon talks briefly about the event, thanking all of those who help make it happen – which is much appreciated by all of us who just attend. Then there is the prize table, which is a feature of the Gathering. Everybody is encouraged to bring something (generally a game, of a quality that they would be happy to receive) for the prize table and everybody gets to take something away with them. The winners of the formal tournaments get to pick first and then everybody else chooses, in a random order. My choice this year was a pack of the Asmadi Games edition of *Innovation* (which I prefer to the one from Iello) and its two expansions. Excellent – and already in use at Swiggers.

With the prizes out of the way, the Gathering begins to wind down, with people packing up and saying their goodbyes. Sunday has a real end-of-term feeling as many people leave on Saturday evening or early in the morning. The piles of games are much smaller and sparser and the hotel is beginning to restore some of the rooms to their normal layout. There are still plenty of people about, though (and a sizable contingent stays until Monday).

I got in a couple of games before it was time to head for the airport. The return journey went without a hitch, my flight landing in Heathrow a good twenty minutes ahead of schedule. And that was that for another year: lots of excellent games played and much fun had!

Many thanks to Alan Moon and team for all their hard work and I look forward to seeing everybody next year.

This article concentrates on the new games I played. My full report is available on my website: www.pevans.co.uk/Reviews/GoF13.html (and as a PDF document).

Boozers and Bellringers

The Fleur is packed in the third week when Quasi Le Bossu hosts the AGM of the Boozers and Bellringers. Quasi and Guinevere welcome everybody before getting down to the serious business. The guest list starts with Arsène Est, who's unaccompanied as his courting has not been successful – and he now has a duel scheduled with Donald O'Grady. Chopine Camus is next, arriving with Sheila Kiwi. Charles Rabbit-Vacuum brings Lucy Fur. Then Donald rolls up. He is on his own because, not only did he meet Arsène on Jacky's doorstep, but Di Lemmere heard what he was up to and gave him the order of the boot. Ava Crisp accompanies Dexter Sinistre, unaware that Dexter was pressing his suit (unsuccessfully) elsewhere earlier in the month. (Yes, that's what happened to the money he borrowed.)

The next guest (alphabetically) is Etienne Brule, who escorts Frances as usual. Frele d'Acier brings Freda de Ath. On the topic of micro-breweries, Frele recommends The Brasserie d'Oc as providing good quality beer. And, incidentally, being the d'Acier family business... When the other guests start good-naturedly checking their bread rolls at him, he protests that his father's only a small merchant and could do with the business (elevating him to wealthy merchant, hopefully). Gaz Moutarde brings Anne Tique to join the discussion. Jacques As escorts Thomasina Tancenjin. Josephine is on the arm of Lothario Lovelace once more.



Monty Carlo is accompanied by Charlotte de Gaulle and doesn't stray from her side. Belle arrives with Pierre Bezukhov II. Uther Xavier-Beauregard is unaccompanied, but that's not for want of trying. Sadly, the object of his affections is never at home when he calls. Was Nae Me is the last on the list and offers to show the assembled guests just how a micro-brewery can take off. This involves "a vessel containing manure with a suitable area above for gas collection, sitting on top of that you have two sacks of compressed flour." Supply a spark from the micro-brewery and "ignition followed by lift-off" will ensue. This is considered to be ingenious, but not quite the point of the discussion.

Conspicuously not present at the AGM is Sheikh Yadik Al-Abowt. Quasi refuses him entry until the matter of his membership has been resolved, even if he has got Ali "The Axe" looming over his shoulder. This is the topic for discussion in the last week. Quasi expects the 'executive' of the Boozers and Bellringers to join him at the Fleur. Only Lothario appears and he's not on Quasi's list this week!

Apart from Quasi, several other members complete their January in the Fleur. As well as Count Shitacks and Madelaine, Euria attends, bringing Edna for the second week in a row. Maggie Nifisent is there with Gar de Lieu as well.

Several members visit the Fleur for a hair of the dog after the New Year celebrations. Count Gar de Lieu brings Mlle Maggie Nifisent for a drink or two before heading off to inspect the statue of the late Indie Spencible he has commissioned. Mlle Madelaine de Proust accompanies Count Jacques Shitacks and they party away in the Fleur all month. Earl Pierre Cardigan escorts Mlle Fifi for a quick drink. Baron Pierre le Sang has Mlle Kathy Pacific on his arm.

There are no parties at Bothwell's, but there is some gambling. Sir Etienne Brule is the man with the wager. Accompanied by Mlle Frances Forrin, he strides to the gaming tables and lays down a 500-crown bet. He wins that one, so he does it again. This time he loses, but he bets again: another win. A fourth bet sees a high roll from the house and Etienne cuts to leave himself up on the week's gambling. Three other members – and their ladies – are in Bothwell's to witness this. Baron Connor McKnight has Mlle Emma Roides on his arm. Earl Eglise de Sant-Suplice escorts Mlle Leia Orgasma. Mlle Laura de Land accompanies Sir Jacques le Franc.

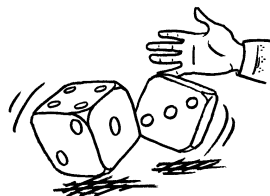

Hunter's is empty this week, but Lothario Lovelace takes Mlle Josephine de Buonoparte to the Blue Gables for a drink. Mlle Marie Antoinette gets a trip to Red Phillis, thanks to her beau, Marmotte d'Ai.

Hunter's fills up in week 2 when Sir Monty Carlo hosts the Minor Saints' Society to celebrate the feast of St Hilary of Poitiers, the "Hammer of the Arians". Mlle Charlotte de Gaulle joins Monty to greet a congregation who all firmly believe in the Trinity. Armand Slice is first, alphabetically, and escorts Mlle Mary Huana. Bill de Zmerchant arrives on his own and promptly proposes a toast to St Hilary – he is later heard asking where Aria is. Dick D'Asterdly is also alone. Edna is with Euria Humble. Josephine accompanies Lothario Lovelace. Marmotte d'Ai takes Marie up market by attending. Pierre Bezukhov II brings Belle and Sebastian Nuisance brings up the rear on his own – celebrating his birthday as well. Sebastian's courting went awry when he met Was Nae Me on Ada's doorstep. Neither man would give way to the other and a duel is required.

Connor McKnight and Etienne Brule are back in Bothwell's with Emma and Frances, respectively. A couple of other members come in, too. Marquis Eric de Miabeille brings Mlle Anna Rexique. Sir Richard Shapmes escorts Mlle Ella Fant. Etienne goes for another series of wagers, but isn't as lucky as he was the week before. He wins the first bet, but then cuts three in a row to finish out of pocket. Eric takes a keen interest in his presence: they are regimental enemies! A series of insults is followed by the requisite challenges.

As well as Jacques Shitacks and Madelaine, the Fleur sees several members return after their visit the previous week. Gar de Lieu brings Maggie, Pierre le Sang has Kathy on his arm and Sheikh Yadik Al-Abowt escorts Katy – though without any Toadies this time.

Reading Matter

My latest bedtime reading has been the 18th in Lindsey Davis's series about her Ancient Roman private eye, Marcus Didius Falco: *Saturnalia*. Back in Rome for once, Falco's new case takes place against the run-up to the annual festival of Saturnalia – some aspects of which still survive in Christmas – and the event itself. Falco is brought in to find a high-ranking German priestess who has escaped captivity in Rome. Probably because she learned that she was to be paraded at the Triumph of the general who captured her and then executed.

There are a few complications. For a start, Falco is in competition with his arch-enemy Anacrites, the Emperor's Chief Spy. Second, Falco has met the escapee before, on his venture into free Germany (in *The Iron Hand of Mars*, the fourth Falco book), and owes her a favour. And his now brother-in-law still holds a torch for her from that previous encounter. Finally, there's a dead body, apparently murdered by the escaping priestess.

All this and the Saturnalia festivities to organise! In fact, much of the story is about the families of Falco and his wife, Helena Justina, and the details of Roman life. Spread over a week, Saturnalia is a major event in the Roman year. Each day involves specific activities as well as much feasting and drinking.

However, it's the whodunit plot that drives the narrative. Falco explores his leads only to find that each is a dead end, until he comes back full circle to where the story started. Here, at last, he finds the clue that breaks the case and, with the help of family and old friends, brings it to a conclusion. Along the way, he gets to explore some of the darker side of Rome and resolve some incidental mysteries.

I've found the last couple of Falco books a bit disappointing, but *Saturnalia* is a glorious return to form by Lindsey Davis. It is an engaging and fun story, set against the colourful backdrop of Saturnalian revelry. Some wonderfully comical moments that combine both the festivities and the murder mystery plot are woven into the story. I enjoyed it a lot and am only disappointed by the knowledge that I have just two more Falco books to come.

Games Events

There are two board games events towards the end of June. Triple-B Con is "Southend-on-Sea's 1st Annual Boardgaming Convention." It's at the Skylark Hotel in Southend over the weekend of 22nd-23rd June. It appears to be essentially an open gaming weekend in what looks like a pleasant (and recently refurbished) hotel. Triple-B, by the way, seems to stand for "Beer, Boards and Bellylaughs" and you can't argue with that! For more information see the website at www.bbbcon.org.uk

Their competition is the well-established Raiders of the Game Cupboard, holding their 23rd quarterly board games day on 22nd June at The Salvation Army

Citadel in Burton-upon-Trent. Supported by Spirit Games, whose shop is just round the corner, this is a day of playing games of all sorts. There's lots of information on the website at www.raidersofthegamecupboard.co.uk

July starts with Summer Stabcon on the first weekend: 5th-7th July at the Britannia Hotel in Stockport. It's a while since I've been to Stabcon, but it is always great fun with a mixture of board games, CCGs and role-playing in good company. To find out more, sign up for the stabconinfo group at Yahoo! (<http://games.groups.yahoo.com/group/stabconinfo>).

And then there's Manorcon on 19th-22nd July at Stamford Hall, University of Leicester. This is the 31st event: the details are at www.manorcon.org.uk

This box concentrates on events I expect to attend.

Swiggers: games club that meets every Wednesday evening, usually upstairs at The Shipwright's Arms, 88 Tooley Street, London SE1 2TF (a few minutes' walk from London Bridge station). Board games and very occasional role-playing. No charges, all welcome. For more information, see www.pevans.co.uk/Swiggers.

Games Games Games Days: from noon(-ish) on the second Saturday of most months at the Allsop Arms (137 Gloucester Place, London NW1 5AL). The pub has an extensive menu as well as good beer and is convenient for Baker Street and Bond Street Tubes as well as Marylebone station. An excellent afternoon.

UK Games Expo: late May at the Hilton Metropole at the NEC. This is a public event that showcases games of all sorts with traders, demos and participation games plus guests. For gamers there are lots of tournaments and open gaming on the Friday and on Saturday evening. For details see www.ukgamesexpo.co.uk

Spiel: the board games event of the year. 24th-27th October 2013, at the Messe (Exhibition Centre) in Essen. Contact Friedhelm Merz Verlag, Postfach 210250, Bonn, 53157 Germany or see www.internationalespieltage.de.

MidCon: 8th-10th November 2013 at the Hallmark Hotel in Derby. MidCon is a friendly board games convention in a decent hotel. See www.midcon.org.uk.

For more extensive information on UK board games events, try the following.

The Labyrinth: <http://homepage.ntlworld.com/the-labyrinth/games/>

The Queen's Lane Advertiser: <http://www.boardgamers.org.uk/qla.php>

Credits

To Win Just Once issue 135 was written and edited by Pevans. The LPBS masthead (page 24) is by Lee Brimmicombe-Wood as are the illustrations on pages 21, 26, 27 and 28. The drawing on page 25 is by Tim Wiseman. Game and book artwork is courtesy of the publisher. Except where noted, photographs were taken by Pevans, who also played with Photoshop. © Paul Evans, 2013

responds with a slash – the first part of a furious slash. Both men's cuts hit at the same time, but the sabre does a lot more damage. Both men recover and regain their ground. Brule blocks while he examines the damage. Only after this does Miabeille slash for his third hit. Brule concedes the duel.

Musketeers lose another one

After the excitements of December, January seems rather tame. Guards Brigadier Ali Vouzon decides that Brigade HQ should accompany the Royal Foot Guards to the Pyrenees. Colonel Devlin Carnate pauses only to admit the mysterious 'X2' to the regiment. 'X2' can't afford a Subaltern's rank and serves as a Private. He is one of the first to pack his kit ready for action. However, RFG Lt-Colonel Amant d'Au doesn't seem to have seen the announcements and is surprised to be marched south from Paris. Major Voulo Vault is already on the frontier and expects to join his regiment. As he's also Guards Brigade Major, he actually serves with Brigade HQ.

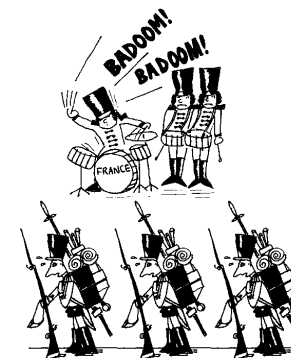

The King's Musketeers suffer another defection as the regiment's second in command, Major Eglise de Sant-Suplice, resigns his commission. Not for long, though, as he joins the Crown Prince Cuirassiers and buys his way back to Major, becoming second in command of the cavalry regiment. Heavy Brigadier Bill de Zmerchant then appoints him Brigade Major, which means he's no longer second in command – nor Aide to General le Matelot. New boy Was Nae Me joins the Grand Duke Max Dragoons, courtesy of Colonel Chopine Camus. He buys a Captaincy. Dick D'Asterdly misses out as his application to the Archduke Leopold Cuirassiers is rejected.

Around the clubs

In Paris's clubs the new year starts quietly enough. Viscount Egon Mad 2 holds forth on his new hangover cure in the Fleur de Lys. His attentive guests are Count Euria Humble and Sir Quasi Le Bossu. Both have brought their mistresses with them, but the ladies are not so interested in Egon's discourse. Talking amongst themselves are Mlle Edna Bucquette, Euria's companion, and Mlle Guinevere d'Arthur, escorted by Quasi. Egon is also able to pass on the news that the good ship "Fair Wind" is reported to have arrived safely in the Caribbean some months before. He is surprised that neither of his guests is, like him, an investor in the Three Sails Trading Company set up by the late Jean-Luc Beauchamp L'Rojik. A more secluded part of the club is where Sheikh Yadik Al-About (who does hold some shares in Three Sails) and new Subaltern Pierre Bezukhov II are cloistered, also with female company: Mlle Katy Did with the Sheikh and Mlle Belle Epoque accompanying Pierre.

Les Petites Bêtes Soyeuses 263

Being a postal game of *En Garde!* run by Pevans since April 1986 and now published as part of *To Win Just Once*.

New players are always welcome. If you'd like to play, you'll need to subscribe to *TWJO* (see the back page). You will also need a copy of the published rules to *En Garde!* (see www.engage.co.uk).

Orders for February 1666 to Pevans at 180 Aylsham Drive, UXBRIDGE UB10 8UF, UK or lpbsorders@pevans.co.uk by Friday 28th June 2013



January 1666

The new year starts with affairs of honour being settled. Nothing new there! Cardinal's Guard Lieutenant-Colonel Arsène Est meets Lt-General Donald O'Grady over the matter of Jacky Tinne. Est brings a sabre and Pierre Cardigan. O'Grady brings a two-handed sword, Etienne Brule and Uther Xavier-Beaugard. Est is clearly the bigger man, but is still carrying some old wounds, which may help O'Grady. As it is, Est starts with a furious slash. The slash hits O'Grady before he can get his heavy blade moving and he surrenders. That didn't take long.

Est is not involved in the King's Musketeers versus Cardinal's Guard duels that follow. First up is a rapier fight between KM Major Eglise de Sant-Suplice and turncoat CG Major Sheikh Yadik Al-Abowt. Both men are slightly built; both have unhealed injuries from previous months. Only Al-Abowt has a second: his junior colleague, Pierre Bezukhov II. Sant-Suplice goes for a parry. Sound idea, but Al-Abowt doesn't attack immediately. Sant-Suplice drops his guard to prepare an attack and Al-Abowt runs him through with a lunge. Sant-Suplice concedes and that's the end of that. The more so as Sant-Suplice cannot now face Euria Humble. Rick O'Shea's challenge to Al-Abowt has been voted cause by Paris, but the Sheikh refuses to meet him.

This leaves Dragoon Guards Captain Etienne Brule taking on Queen's Own Carabiniers Colonel Eric de Miabeille. O'Grady re-appears as Brule's second, holding his jacket as he draws his rapier. De Miabeille, on the wrong side of the size difference, at least has a sabre as his weapon. Brule scores first blood immediately by starting with a furious lunge. Stabbed by the lunge, Miabeille

The Light that Failed

Star Trader game 6 – Turn 8

"Well that was an easy trip after all."

"A relief"

"Now, where is the rendezvous point?"

The Operations Officer checked the screen and pointed his finger.

"Actioned."

The ship changed direction and began to slow.

At Gamma Leporis, GATES-LEARJET sold 6 Alloys surprisingly for 1 HT each and gained a Dealership.

HOLYOKE ARBITRAGE sold 2 Isotopes for 5 HTs each at Epsilon Eridani as prices generally rose in the system.

QUASAR sold an Alloy for 12 HTs at Tau Ceti. Isotopes were much more popular. First HOLYOKE ARBITRAGE bought 12 HTs for 3 HTs each to gain a Contractor position, then GATES-LEARJET bought another 3 at the same price to become Dealers. QUASAR's bid of 1 HT to buy was too low, while BELISAR POLITICAL bought 5 on Contract.

Mu Herculis saw HOLYOKE ARBITRAGE buying 8 Monopoles for 14 HTs apiece and gaining a second Contractorship. MONOGRAM then sold 12 Monopoles for 10 HTs each, allowing the ASSOCIATION OF INTERSTELLAR ANARCHISTS to buy 2 Monopoles at 10 HTs.

GATES-LEARJET sold a Spice for 10 HTs after which BELISAR sold 2 for 11 HTs each. HOLYOKE ARBITRAGE bought 5 Spice on Contract.

BELISAR sold 11 Isotopes for 5 HTs each and a Dealer's position at Beta Hydri and then sold 4 Monopoles for 18 HTs apiece. The AIA sold 9 Monopoles at the same price and gained a Dealership. MONOGRAM's bid was too late to be considered. ARCHANGEL sold 9 Spice for 14 HTs each, gaining a Contractorship, and MONOGRAM sold 2 more at the same price. The AIA bid of 16 was too high.

THE ASSOCIATION OF INTERSTELLAR ANARCHISTS repaired their Sword Hull in the Tau Ceti Shipyards, paying from their secret funds for exemplary work and discarding their damaged pod. They also squeezed out a purchase of a Warehouse at Beta Hydri.

HOLYOKE ARBITRAGE took the Opportunity to buy a Battle Comm pod at Mu Herculis using OP 21. They jumped their armed merchantman first to check if the space was clear.

ARCHANGEL LINES had to pay up to all the passengers who they failed to deliver. Since the emergency Hyperjump avoided conflict with the AIA, ARCHANGEL may think it cheap. They embarked passengers to Epsilon Eridani, Beta Hydri and Tau Ceti, buying 2 Passenger pods for the Cathy Jones.

QUASAR ENTERPRISES bought 3 Isotope Factories at Tau Ceti and 2 Alloy Factories at Gamma Leporis.

MONOGRAM INDUSTRIES equipped the Brighthon with Augmented Jump, Passenger, Cargo and Light Weapon Pods and A class crew.

GAMLEPCO got round to buying an Augmented Jump Pod for the Aleph.

Press

AIA to Quasar: oops! We seem to have dropped your spaceship. And we had such great plans for it (involving some black, black paint, very loud rock music and a rendezvous with a star...).

Just wondering about the wisdom of buying more ships.

“Damn those Anarchists,” mused Boris J Son in his 18th floor office at Quasar Enterprises, overlooking the ocean on Sigma Draconis. “All that lovely wine, synth drugs, not to mention that zero-gravity water bed I had imported from Beta Hydri for my trysts with Penny Jugs from the Procurement team

aboard the Magic Flute – ‘just working late dear, yes, yes, don’t worry’ – vaporised as B’stard in Accounts refused to authorise his request to pay the AIA a finder’s fee!! And the bed was on a 3-month sale and return.” After the debacle with the Boris Bikes scheme – due to the acid rain from the now defunct Isotope mines corroding the wheel spokes and the lawsuits from damages as the tourists fell off as the bikes collapsed – it was not looking good. Whatever next? “No wonder I’m going grey,” mused Boris...

Freedom for Sigma Draconis!

Corporation Table

Corporation letter and name	Connections Bus/Crim/Pol	Init ^v Bid	Turn order	Cash Rep ⁿ	Player
A Archangel Lines	6 0 3	3	5th	381 40	Howard Bishop
B Monogram Industries	9 0 4	0	7th	242 34	Andrew Burgess
C Quasar Enterprises	10 0 5	10	1st	203 36	Mark Cowper
D Belisar Political	10 0 9	+4	3rd	306 40	Mike Dyer
E GamLepCo	5 0 5	2	8th	81 28	Martin Jennings
F Holyoke Arbitrage	10 8 2	10	2nd	44 40	Przemek Orwat
G Gates-Learjet	10 4 2	0	4th	122 32	Bob Parkins
H Association of Interstellar Anarchists	3 6 9	0	6th	59 N/A	Paul Evans

N under Initiative Bid means No move received, F indicates the Corp was floated

News

There were four new News chits this turn. Current chits are (new in bold):
 Turn 9 P3
 Turn 10 C4, **C6**
 Turn 11 **C3, B4**

Turn 12 **P4**
 (Chits are identified by the Connection type and level required to see them and disappear/take effect in the News Phase of the turn listed.)

40	2D	Inverness	KC	Dundee
41	QD	Aberdeen	4S	Castle Douglas
42	KD	Aberdeen	2H	England
43	QC	Dundee	QH	Edinburgh
45	10C	Tyndrum	AS	Ireland

You may enter up to 6 races (plus any held over – shown in italics). Races that are struck out cannot now be run. After the races, you may build up to 4 points, including known payments to rivals.

GM Notes

Leapfrogs used: None.

Races continue this turn. The nature of the map means joint runs are likely. Please make sure that such races are listed in BOTH sets of orders – though the route only has to be in one set; the second set can say to use the route given by the first player.

Races that cannot be run because no one has connected to them remain available and do not count against the limit on the races you can enter each turn.

**Orders to Mike Dommett, 119 Victoria Road, ALTON GU34 2DD
 or by e-mail to mike_dommett@yahoo.co.uk by 21st June 2013**

Games from Pevans

Mail order board and card games in the UK



new Bora Bora

The latest from Stefan Feld and alea, *Bora Bora* is set on a South Seas archipelago. Players have just six turns to maximise their score across the different activities and the final bonuses (no mean feat, you can’t miss a turn). I look forward to playing it a lot more.

For 2-4 players, aged 12+, playing time 25 mins/player: **£40.00**



new Colonial

The subtitle, “Europe’s Empires Overseas”, gives a good idea of what *Colonial* is all about. It’s a game of exploration, trade and colonisation, played out across a map of the world as the European nations build their empires.

For 2-6 players, aged 13+, playing time 2 hours: **£53.00**

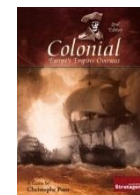

Online at www.pevans.co.uk/Games

Kingsley Halt

Railway Rivals game 9 - Turn 10

Many more joint runs and a surprising win for McJacobahn puts him just ahead of the North British Railway Company. A strong turn for Wishie-Washie brings him closer, but he may regret not building to Skye, which is now inaccessible to anyone. McJacobahn bought an Irish ferry, which might prove worthwhile.

Race results

Race	From	To	Jacob	Wishie	NBR	PFB
17	JD Fraserburgh	3H Carlisle	+5		10-3 JR	10-2 JR
25	6S Ardrossan	AD N Scotland		20		
26	7H Gala	2C Fort William	10 JR	10 JR		
27	6H Hawick	5S Ayr	20			
28	5D Aviemore	10S Airdrie		20		
29	JD Fraserburgh	7H Gala	10 JR		10 JR	
30	5C Dumbarton	KH Edinburgh	20-3	+3+3	0-4	10 +1
31	2C Fort William	6D Pitlochry		20		
32	KS Glasgow	8D Montrose			20	
33	8H Peebles	3C Oban	+4	10-2 JR		10-2 JR
34	9S Motherwell	9H Berwick	+6			20-6
35	8C Dunfermline	QS Glasgow		+3	20-5	10-3+5
Total			72	87	48	53

Builds

McJacobahn - Mark Cowper (Blue)

Builds: Ferry Stranraer - Ireland
POINTS: 217 -6 +72 = 283

North British Railway Company - Jonathan Palfrey (Green)

Builds: None
POINTS: 234 +48 = 282

Weeshie-Washie & Coldness Railway - Thomas Kok (Black)

Builds: None
POINTS: 161 +87 = 248

Premiership Football is Best - Gerald Udowiczenko (Red)

Builds: None
POINTS: 164 +53 = 217

Next turn's races

Race	From	To
11	AS Ireland	QD Aberdeen
24	AE Skye	ZB Inverness
36	3S Wigtown	4D Elgin
37	6S Ardrossan	9C Kirkcaldy
38	AH England	AD N Scotland
39	JH Edinburgh	AE Skye

Orders to Mike Dommett, 119 Victoria Road, ALTON GU34 2DD or by e-mail to mike_dommett@yahoo.co.uk by 21st June 2013

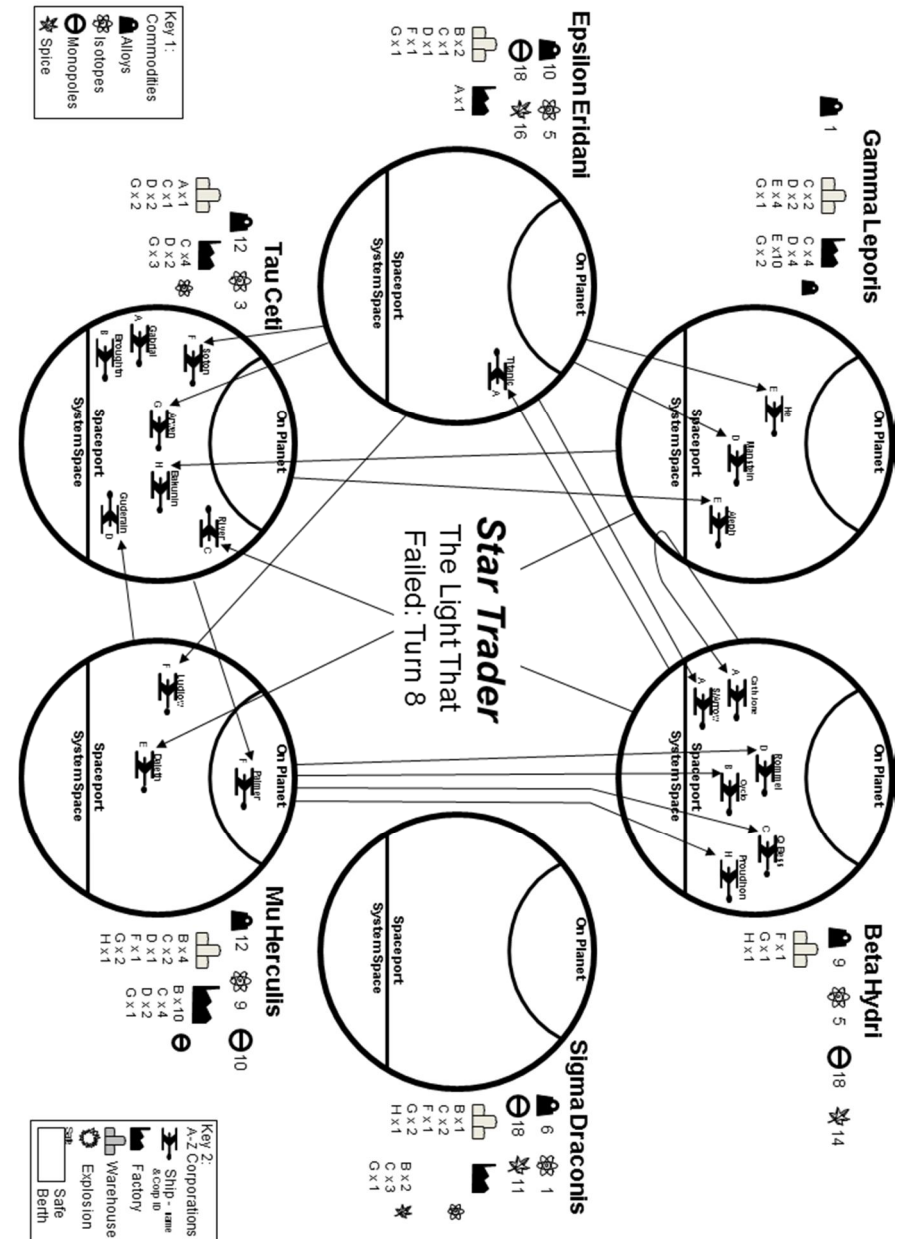

The Bonking Game

Turn 8

There seems to be a target this turn. Mike Dommett bonks Mike Dyer: “he has no bonks of any sort. It is my DUTY to give him some.” Andy Kendall bonks Mike Dyer: “no-one should go bonk-free for two turns running!” Nik Luker has different reasons, but the same target: “Mike Dyer ’cos I don’t think I’ve bonked him yet...” Graeme Morris is analytical: “working my way down the list of ‘suspicious double-zeroes’ I opt to bonk, bash or even blat Mike Dyer. So ‘TYF’ (anyone remember that one?).” I do: a fine ’zine published by John Harrington and Kevin Warne. Or did you mean the *Tunnels & Trolls* spell?

Finally, Matt Shepherd opts for Mike Dyer “for reminding me how irritating Danny Dyer is.” With five bonks, Mr Dyer is out. His parting shot is Mike Dommett “for spreading false rumours about the chairman of Belisar Political. It was not I who turned up later at the spaceport wearing nothing but a pair of dress shoes. What happens in the spice dens of Epsilon Eridani stays in the spice dens of Epsilon Eridani.”

Bill Hay has it in for Mike Dommett as well: “in the hopes of initiating a grand alliance against the smug zero self-bonkers.” Bill is the target for Chris Baylis: “for having the audacity to kick me (Games Gazette/SEWARS) when it is down – the nerve of the guy.” He has further demands: “as I missed last issue’s Bonking can I give Bill Hay two bonks this turn? Please...? Pretty please, pretty please with very expensive, direct from Canada, Maple Syrup and a Raspberry on top please?” No.

Brad Martin has Mr B in his sights: “So close I can’t resist – a great big bonk to Chris Baylis.” Meanwhile Andrew Burgess sends a limerick. “After working hard for a day,/In the evening at home I did stay./My glasses of beer/Filled me full of good cheer,/So I decided to bonk William Hay.” The Swiss jury, aka Martin Jennings, votes for Paul Wilson – “As he seems to keep a grudge for a long time, here is more fuel for the fire.” Tim Macaire aims in the same direction: “Paul Wilson for impersonating the GM by being called Paul.”

Paul Wilson’s own nomination is Tim Macaire “as it seems no one has picked them yet.” Well, they’re doing it this time! Colin Bruce bonks Tim Macaire “for hiding in a cupboard this far!” Mark Cowper bonks Tim, too: “No votes, scandalous!! No time for doughnuts.” Doughnuts?!

Al Tabor seems to be singing from a different hymnbook as he bonks Graeme Morris. “Are we sure he’s not really Morris Graeme?” he asks. And Matt Wale bonks Martin Jennings: “frankly I have run out of ideas as to who to go for so I’ll just do the same poor chap again.”

Mike Dommett adds: “Mr Cowper may have qualified for the Gerald Udowiczenko die.”

This turn’s scores

Player	Self	Total
Chris Baylis	2	3
Colin Bruce	1	1
Andrew Burgess	1	1
Mark Cowper	1	1
Mike Dommett	0	2
Mike Dyer	0	5
William Hay	1	3
Martin Jennings	1	2
Andrew Kendall	0	0
Nik Luker	0	0
Tim Macaire	0	3

Player	Self	Total
Brad Martin	1	1
Graeme Morris	1	2
Matthew Shepherd	1	1
Alan Tabor	1	1
Matthew Wale	0	0
Paul Wilson	0	2

Self is the number of self-bonks (to date); Total is the number of bonks this turn.

What’s this about?

The name of this game goes back to more innocent times and the game has also appeared under other titles. Each turn, each player bonks (= nominates) another recipient of this magazine who’s still in the game. Those who are bonked enough times in a turn are out and can’t bonk anyone else. Last man standing wins.

The game is open to anyone who receives *To Win Just Once*. Players just have to send me the name of another *TWJO* recipient (from the list above) and give a reason (it doesn’t have to be significant). Players who don’t bonk someone else bonk themselves (and self-bonks are cumulative from turn to turn). The nominations needed for ejection will reduce as the number of players goes down.

(If you read *TWJO* and I’ve left you out of the list, drop a line to TWJO@pevans.co.uk and I’ll add you in next time. If you don’t want to be included, just wait and you’ll be out next turn.)

**Send your bonk to Pevans at
180 Aylsham Drive, UXBRIDGE UB10 8UF or
to TWJO@pevans.co.uk by 21st June 2013**

