

That would be enough

This has been issue 149 of *To Win Just Once*, published 24th October 2014. It incorporates *Les Petites Bêtes Soyeuses*, a game of *En Garde!*. Issues are published ten times a year, roughly every five weeks. © Paul Evans 2014

Deadlines

Orders for *Railway Rivals* and *Star Trader* to Mike by 7th November 2014.

Orders for *LPBS*, Fictionary Dictionary votes and entries and any other contributions to Pevans by Friday 14th November 2014.

(Last 2014 deadlines: 12th/19th Dec. First in 2015: 23rd/30th Jan)

Waiting lists

En Garde! new players are always welcome in *Les Petites Bêtes Soyeuses*. You will need the rules to *En Garde!* in order to play: www.engarde.co.uk

Railway Rivals – Martin Jennings, Mike Dyer and Jonathan Palfrey are in the frame for the next game. Working map and rules provided.

Star Trader – Mateusz Ochman and Rob Pinkerton are waiting for the next game – anyone else? Rules provided.

Online games

See page 19 for more information about these.

Brass at brass.orderofthehammer.com

Puerto Rico at www.pr-game.com

Through the Ages at www.boardgaming-online.com

Agricola (at www.boiteajeux.net): Pevans

Nauticus, *Roll Through the Ages* and *Vinci* (at www.yucata.de) Pevans.

Credits

To Win Just Once issue 149 was written and edited by Pevans. The *LPBS* masthead (page 22) is by Lee Brimmicombe-Wood, as are the drawings on pages 18, 23, 25 and 28. The illustration on page 27 is by Tim Wiseman. Game and book artwork is courtesy of the publisher. Pevans took the photographs (except where noted) and played with Photoshop.

Printed and published by Margam Evans Limited

(A company registered in England and Wales, number 05152842,

Registered office: 180 Aylsham Drive, Uxbridge UB10 8UF)

Tel: 020 7183 6256, E-mail: TWJO@pevans.co.uk, Web: www.pevans.co.uk/TWJO

To Win Just Once

(incorporating *Les Petites Bêtes Soyeuses*)

YUNNAN

Pevans reviews
Yunnan

Argentum Verlag

A game for
hard-boiled tea traders
by Aaron Haag

Contents

Chatter..... 3

Letters..... 4

Reading Matter..... 4

All the Tea in China?..... 6
Pevans reviews *Yunnan*..... 6

Games Events..... 11

Fictionary Dictionary 12
Round 10..... 12

Medstead and Four Marks..... 14
Railway Rivals game 10 – Turn 8 14

Close to Critical..... 15
Star Trader game 7 – Turn 8..... 15
Star System Map..... 17

Subscribing to TWJO 18

Online Games..... 19

Les Petites Bêtes Soyeuses 22
April 1667 (278)..... 22
Press 30
Points Arising..... 33
Announcements..... 34
Duels 34
New Characters..... 35
Tables..... 35
Other Appointments 35
Army Organisation and 1667's summer Deployment 36
Brigade Positions 36
Frontier Regiments..... 36
Battle Results..... 36
Regiments..... 37
Femmes Fatales 37
The Greasy Pole 38

That would be enough 40
Deadlines 40
Waiting lists 40
Credits 40

ID	Name	SL	SPs	Cash	Rank,	Regiment/Appointment	MA	Last seen	Club	EC	Player
JJ	Sir Jean Jeanie	14+	47	Comfy	Major	RFG	8	Lotte	Both	3	Andrew Kendall
JA	Jacques As	13	35	Comfy	Major	GDMD	1	Thomasina	Both	4	Joe Farrell
CC	Chopine Camus	13	31	OK	B.Bdr-General	GDMD	4	Sheila	Both	4	Stewart Macintyre
MC	Baron Monty Carlo	13	25	Withy	B.General		12	Charlotte	Hunt	4	Andrew Burgess
LL	Sir Lothario Lovelace	12	30	Comfy	Major	CG	7		Both	4	Geoff Bowers
TM	Sir Tourtière Mangetout	12	24	Withy	B.Bdr-General	53F	3	Sue	BG	4	Howard Bishop
HJH	(Hooray) Henri Hardup	11	RIP								Mark Cowper
WJNM	Was Nae Me	10	F	OK	Lt.Colonel	KM	6		Hunt	3	Mark Farrell
RdG	René de Gaviscon	9	F	Comfy	Lt.Colonel	ALC	4		BG	5	David Williams
AS	Arnaud Surfinmaise	9	F	OK	Major	PM	5		BG	5	Nik Luker
BCdT	Bonne Chance de Tres	9+	33	Poor	Major	GDMD/LtGen's Aide (UXB)	6	Pet	BG	1	Cameron Wood
MFB	Maurice Fluff-Bunny	8	19	Comfy	Colonel	13F/Gen's Aide (US)	5		BG	5	Jason Fazackarley
AFD	Allan Fa-Dân	8	8	Poor			6		BG	4	Gerald Udowiczenko
DDA	Dick D'Asterdly	8	F	OK	Lt.Colonel	CPC/Hvy Brigade Maj.	2			4	Gerry Sutcliffe
CDL	Coeur De Lion	8+	25	Poor	Major	PM	4	Ada	RP	3	Graeme Wilson
RdM	Rob d'Masses	7	F	Poor	Captain	QOC	2		HGds	5	Craig Pearson
PN	Pepé Nicole	6	13	Poor	Colonel	69A/4 F Brigade Maj.	5		RP	3	Colin Cowper
KdM	Kidder de Margaux	6	9	Poor	Captain	GDMD	4		F&P	6	Gary Phillips
GLR	Gruaud LaRose	6	F	Comfy	Lt.Colonel	PLLD	3		F&P	4	Neil Packer
MED	Maurice Essai Deux	6	F	Poor	B.Subaltern	KM	4		F&P	3	Olaf Schmidt
PJ	Pierre jambon	4	13	OK	Major	13F	3	Violet	RP	3	Chris Carter
XSZ	Xavier Self Zeffort	3+	20	Comfy			5	Lois		3	Martin Jennings

An F under SPs means that the character was at the Front, RIP means that he died.

+ against SL means it went up this month, - means it went down.

Cash: Poor = <500, OK = 500-1500, Comfy = 1500-5000, Withy = 5000-10000, Rich = 10000-25000, Flthy = 25000+

Last seen is the lady the character was last seen with in public.

EC is Endurance Class: 1 = <60, 2 = 60-90, 3 = 91-120, 4 = 121-159, 5 = 160-200, 6 = 201+

The Greasy Pole

ID	Name	SL	SPs	Cash	Rank	Regiment/Appointment	MA	Last seen	Club	EC	Player
DC	Count Devlin Carnate	30+	91	Comfy	B.Bdr-General	RFG/State Min.	11		Flr	2	Bruno Giordan
GdLi	Count Gar de Lieu	26	72	Poor	General/Min	w/o Port	8	Maggie	Flr	4	Bill Hay
EM2	Viscount Egon Mad 2	24	52	Rich	Bdr-General/HGds	Brigadier	9		Flr	4	Tym Norris
JS	Count Jacques Shitacks	24	34	Fithy	General		3	Madelaine	Flr	4	David Olliver
JdG	Count Jacques de Gain	23	54	Fithy	Colonel	KM	17		Flr	5	Ben Brown
PC	Earl Pierre Cardigan	22	51	Comfy	General/Fld Army	Commndr	9	Edna	Flr	4	Matt Shepherd
TIM	Earl Tomas le Matelot	22	43	Rich	Fld Marshal		8		Flr	4	Tim Skinner
UXB	Viscount Uther Xavier-B'regard	21	57	Comfy	B.Lt-General/War	Minister	12	Henrietta	Flr	3	Pete Card
PIS	Marquis Pierre le Sang	21	55	OK	General/Min	w/o Port	7	Guinevere	Flr	4	Bill Howell
EH	Count Euria Humble	21	27	Withy	B.Bdr-General	CG	18	Angelina	Flr	5	Matthew Wale
AV	Earl Ali Vouzon	20	60	Rich	B.Lt-General/Insp.	Gen.Inf	5	Jenny	Flr	2	Graeme Morris
AdL	Baron Armand de Luce	19	52	Withy	Bdr-General/Chancellor		6	Frances	Flr	2	Francesca Weal
EdSS	Viscount Eglise de Sant-Suplice	19+	59	Comfy	Colonel	CPC/Min w/o Port	15	Laura	Both	6	Charles Burrows
JIF	Baron Jacques le Franc	19+	58	Withy	Lt.Colonel	RM/1st Div Adjutant	10	Ella	Both	4	Charles Popp
RS	Marquis Richard Shapmes	18	56	Withy	B.General/Min	w/o Port	2	Ophelia	Flr	2	Mark Booth
VV	Sir Voulo Vault	18	44	Poor	Major RFG/Cds	Brigade Maj.	5	Mary	Flr	3	Tim Macaire
BdZ	Baron Bill de Zmerchant	18	36	Poor	B.Lt-General/Fntr	Div Commandr	5		Flr	3	Ray Vahey
AE	Sir Arsène Est	16	41	OK	Colonel	DG/Fntr Div Adjutant	2	Belle	Both	4	James McReynolds
EB	Sir Etienne Brule	16+	49	Withy	Major	RM/1 F Brigade Maj.	3	Anne	Both	2	Mike Clibborn-Dyer
GM	Sir Gaz Moutarde	15	43	Withy	Lt.Colonel	RFG	6	Katy	Both	5	David Brister
AdA	Baron Amant d'Au	15	37	Withy	B.Bdr-General	QOC	13	Anna	Both	3	Pete Holland
EdM	Marquis Eric de Miabeille	15	23	Withy	B.Lt-General		13		Both	2	Pam Udowiczenko
WP	Marquis Warren Peece	15	23	Withy	B.Lt-General		13		Both	4	Mike Dormett
TC	Terence Cuckpowder	15+	52	OK	Lt.Colonel	QOC/Cav Div Adjutant	3	Lucy	Both	3	Peter Farrell
FdA	Frele d'Acier	15+	45	OK	Major	DG/HGds Brigade Maj.	4	Freda	Flr	6	Paul Wilson
ROS	Sir Rick O'Shea	14	36	OK	Colonel	RM/CPS	3		Both	3	Martin Adamson
DOS	Dexter Simistre	14	22	Poor	Lt.Colonel	GDMD	4	Ava	Both	3	Chris Boote
YVB	Baron Yves Vrai Bretheauteque	14	RIP								

Chatter

It feels rather odd writing this now, even before the deadline – it's usually one of the last things I do. However, as I mentioned last time, I'm off to Essen for the Spiel games fair in a few days. So my plan is to get as much of the magazine done before I go. I'll finish it off when I get back and then print and post. You'll know how successful I've been depending on when you get this.

I was right about the latest building work at the end of my road. Last issue I mentioned that the contractors were drilling deep holes across the site. As I surmised, these are now being filled up again: cylindrical cages of reinforcing rods and a lot of concrete. Presumably these are foundations, going down deep enough to get through the clay.

Setting up this issue of *TWJO* has had me cursing Microsoft once again. A few years ago, I spent some time carefully deciding on the best fonts to use for *To Win Just Once* (for the record they are Century Schoolbook for text and Lucinda Sans for headings). My latest acquisition is a nice new laptop. Not surprisingly, it came with Windows 8.1 (hence I got a machine with a touch screen, to make use of the touch features in the software). Guess which fonts are not included with Windows 8.1?

Having said that, Microsoft then came to my rescue. I found the missing fonts as part of Office 2010. Why they didn't install the first time, I don't know, but I've added them and can now work on *TWJO* on both computers.

Meanwhile, it's now only three months to Christmas, which means... mince pie season has started! Yum, yum.

TWJO online

The PDF version of *TWJO* 148 was downloaded 148 (no, really) times in September – it was available from 18th of the month. Issue 147 was downloaded a further 41 times to make 210 downloads in two months. There were 25 downloads for *TWJO* 146, taking it to 145 since publication.

Looking at some of the other statistics, I wasn't surprised to see which pages were popular last month, with lots of people browsing my reports from the UK Games Expo and Gathering. Looking at the countries visitors came from, the USA was at the top, but this is possibly anybody with a .com address. Intriguingly, China was second, well ahead of the UK.

Bizarrely, the top search term used to find my website was "shanendoah games". I have no idea where that came from, let alone what it found on my site! Other visitors were more interested in my first impressions of *Black Fleet* and *Castles of Mad King Ludwig*, both of which will be featuring at Spiel this month.

Letters

Jonathan Palfrey has some comments from Spain on coffee and beer.

Your discovery of Puccino's in Willesden Junction station reminds me that there's another Puccino's on the station platform at Richmond on Thames, where I saw a "Shut happens" sign a few years ago (and took a photo of it). At the time, I assumed it was the whim of some individual employee; I'm rather disappointed to find that it seems to be a company standard.

I still find it amusing – though it does wear off with repetition.

You may or may not remember that I'm mostly unfamiliar with British beer, having had experience almost entirely of Continental lager (though I usually prefer wine). However, I was over in England for a while in July/August, to try to sort through the possessions of my late mother, and I bought some beer more or less at random in a local shop. I tried Sharp's Doom Bar amber ale (4.3%) and Wychwood Brewery Hobgoblin Gold (4.5%), both of which I liked better than the run-of-the-mill English beers I've tried occasionally in the past. In fact, I repeated both of them. A pity I can't easily get that sort of thing here.

Both beers I really enjoy. Doom Bar has had wide distribution since Molson Coors bought the Sharp's brewery in 2011. And I've really enjoyed Wychwood Brewery's advertising, which emphasises that Hobgoblin's a real ale: "What's the matter, lager boy – afraid you might taste something?"

Tim Macaire chips in on my latest rant...

Your diatribe against monosyllabic "our" reminds me of the apocryphal southerner who asked why first names starting with R were so popular in *Coronation Street*: there's R Lisa, and R Hayley, and R Roy...

R Ena, R Hilda and R Len in my day...

Reading Matter

The latest tome on my bedside table has been the 650-odd pages of David Brin's *Existence*. It's taken a while to get through this, reading a few pages last thing at night. Essentially, this is a near future tale of first contact with aliens. Except that it's rather different from any other first contact story I've read.

The novel is divided into several parts, but is further divided within this. Apart from the chapters of the narrative, there are other pieces of text spliced into the interstices between them. Many of these appear to be part of the story, hinting at other players in the plot and what they might be up to. Other pieces include a continuing dialogue about the Fermi Paradox – if there are aliens out there, why can we find no sign of them? –

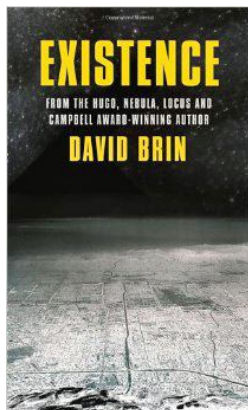

Frontier regiment 4: 5
RNHB regiment: 2

Femmes Fatales

No	Name	SL	Attr	Last
64	Edna Bucquette	18	W	PC
3	Kathy Pacific	17	B	
54	Madelaine de Proust	17		JS
35	Katy Did	16	I	AdA
42	Maggie Nifisent	16	B	GdLi
55	Jacky Tinne	16		
52	Guinevere d'Arthur	15	B/W	PIS
10	Frances Forrin	14	B	EdSS
21	Helen Highwater	14	W	
48	Fifi	14	B/W	
62	Alison Wunderlandt	14		
11	Laura de Land	13		JIF
16	Ophelia Derriere	13		VV
26	Ella Fant	13	B	RS
27	Lucy Fur	13	B	TC
30	Leia Orgasma	13	B	
45	Cath de Thousands	13		
8	Lotte Bottle	12	B	JJ
12	Charlotte de Gaulle	12		MC
17	Henrietta Carrotte	12	I/W	UXB
28	Vera Cruz	12		
31	Bess Ottede	12	I/W	
1	Sue Briquet	11	B	TM
4	Anne Tique	11	W	GM
9	Deb Onairre	11	I	
40	Sheila Kiwi	11		CC
63	Carole Singeurs	11		
20	Emma Roides	10	I	
33	Anna Rexique	10	I	EdM
38	Pet Ulante	10	W	BCdT
43	Di Lemmere	10	I	
53	Angelina de Griz	10	B	AV
56	Ingrid la Suede	10		
6	Viv Ayschus	9		
57	Ava Crisp	9	I	DS
59	May Banquot l'Idee	9		
2	Betty Kant	8	I	
19	Jenny Russe	8	W	AdL
32	Sal Munella	8	W	
41	Marie Antoinette	8	B/I	
49	Mary Huana	8	B/I/W	BdZ
34	Freda de Ath	7	W	FdA
39	Thomasina Tancenjin	7	I	JA
50	Ulla Leight	7	I	
5	Belle Epoque	6	B/I	EB
13	Josephine Buonoparte	6	I/W	
24	Violet Bott	6	I/W	PJ
15	Ada Andabettoir	5	B/I	CDL
25	Lois de Low	5	B	XSZ

Regiments

Col	DC	EH	JdC	EB	EdM	N7	EdSS	ROS	CC	N2	MFB	CLR	TM	PN+
LCol	AdA		WNM		TC	RdG	DDA+JIF	DS						
Maj 1	VV+	LL	N5	N3	N4	N6	N5	GM+JA	ADL	N1+N2+				
Maj 2	JJ		N2	FdA+N2				N3	BCdT	PJ	N5			N6
Capt 1	N1	N3	N4	N5	N5	N6	N5	N3	N3	N6	N3	N6	N5	N2
Capt 2	N5	N4	N6	N2	N5	N5	N6*	N5*	N3	N5	N4	N1	N6	N6
Capt 3	N1	N4*	N4	N2	N5	N2	N2	N5	N4*	N6	N3		N2	N4
Capt 4	N2*	N3		N2*	N6*	N1*	N2	N2	N2	N3*			N6*	N5*
Capt 5					RdM									N4*
Capt 6														N4*
														N1*

This table shows the ten senior positions in the 17 regiments by rank. Entries are Character abbreviations, N (+MA) for NPCs, blank for vacant. * shows the regiment adjutant; + shows ranks held by characters with a (senior) brevet rank or an appointment elsewhere.

This table shows the mistresses in Paris. B=Beautiful, I=Influential, W=Wealthy; Last=Last lover seen with this month

Army Organisation and 1667's summer Deployment

Field Army (Field Ops)	PC/___/___/N
First Division (Field Ops)	N3/N/JIF
Guards Brigade (Field Ops) – RFG CG KM	
RNHB Regiment (Field Ops)	
Second Division (Field Ops)	N6/N/N3
1st Foot Brigade (Field Ops) – RM PM	
2nd Foot Brigade (Field Ops) – 13F 53F	
Third Division (Field Ops)	N3/N/N3
3rd Foot Brigade (Field Ops) – 27M 4A	
4th Foot Brigade (Field Ops) – 69A Gscn	
Cavalry Division (Field Ops)	N5/N/TC
Horse Guards Brigade (Field Ops) – DG QOC	
Heavy Brigade (Field Ops) – ALC CPC	
Frontier Division (Field Ops)	BdZ/N/EB
Frontier Regiments (Field Ops)	
Dragoon Brigade (Field Ops) – GDMD PLLD	

Organisation and Deployment for the Campaign Season
with Army and Division posts (Commander/Aide/Adjutant/QMG)
Entries are ID for player characters, N (+MA if needed) for NPC, ___ for vacant

Brigade Positions

Guards Brigade	N5/N/VV	First Foot Brigade	N3/N/GM
Horse Guards Brigade	EM2/N/FdA	Second Foot Brigade	N5/N/N1
Heavy Brigade	N1/N/DDA	Third Foot Brigade	N1/N/___
Dragoon Brigade	N4/N/N2	Fourth Foot Brigade	N5/N/PN

Current CO/Aide/Brigade Major of each Brigade; entries as Army table

Frontier Regiments

	F1	F2	F3	F4	RNHB
Colonel	N3	N2	N5	N1	N7
Attached		1 Bn KM	3 Bn KM	2 Bn PM	
			1 Sqn ALC	RdM	
			DDA		
Also at the Front		Princess Louisa Lt Dragoons			

This table shows the Colonels of the Frontier regiments (N+MA for NPCs), together with the volunteers assigned for the season.

Battle Results

Princess Louisa Lt Dragoons: 2
Frontier regiment 1: 5

Frontier regiment 2: 3
Frontier regiment 3: 3

and possible reasons for it. And excerpts from a long list of ways humanity could become extinct.

Part one begins our introduction to this near future world, where coastal areas around the planet have been flooded by rising sea levels, the poor are still with us (and even poorer), while the wealthy continue to hoard their riches and get richer and richer, and the few astronauts left have humdrum jobs collecting garbage from Earth orbit. Until one of them, Gerald Livingstone, finds something that isn't of human manufacture.

While this discovery will have a huge impact, Brin initially concentrates on telling us more about this near future world. He introduces a number of viewpoint characters, giving us some very different perspectives on this culture. I wasn't quite sure how it works, but he envisages a global civilisation stratified into several 'Estates', cutting across old ways of organising human society, such as nation states. Thus there is an Estate of billionaires, an Estate of aristocrats and so on in what feels more like a feudal system than present day capitalism. However, it is also a system that is under strain and is attacked by subversives and terrorists.

The main plot gradually gets going as the alien artefact is examined and then activated. It is not at all what I (and, I suspect, most readers) was expecting. Within the story, the device's functioning is also a huge surprise – though at this stage not too many people are aware of it. Eventually, news gets out to the world at large, provoking both predictable reactions (panic, rioting, denunciation – most of which happens off-stage, as it were) and some unexpected ones. Could there be more of these devices? A lot more?

Having started small, Brin is painting on a huge canvas by the end of the book. However, he is still telling us the story using the viewpoints of the characters he introduced originally (or their descendants...). Along the way he addresses some of the questions of how humanity will develop in the future. In particular, we get a different take on Uplift – the intentional development of intelligence in other species that is a major feature of some of his previous novels (and probably the concept that he is best known for).

While I enjoyed the book, I found it rather disjointed. First because of the passages inserted between chapters. They completely change the tone of what you're reading and, while they are generally germane to the story in some way, I found this distracting. Second is the way plot jumps between the parts. Thus, we readers may be getting the build up to major event through one part only to find that, at the start of the next part, the event is already history. Well, what actually happened? We readers never see the event itself; just have it reported to us. These gaps seemed to get bigger as the book progresses, too.

I was also bemused by the way the story swings between optimism and pessimism. That is, in terms of what the book is saying about humanity's future.

I have no problem with this changing, but I couldn't see any reason why it had changed. Thus after much doom and gloom, when things all seem to be getting worse, we suddenly get sunshine and happiness. How did the story get there?

So, overall, an interesting read, but a bit of a disappointment. If you're a fan of David Brin's books, you'll want to read this. If not, I suggest you pick up the Uplift books (*Sundiver* is the first) or *The Postman* (no, really – just put all thoughts of Kevin Costner out of your head).

All the Tea in China?

Pevans reviews *Yunnan*

Yunnan seems to have grown on my games group: it initially had a lukewarm reception, but has now become a staple of our weekly sessions. Let's see if I can give a flavour of its appeal. According to the game, Yunnan produced high quality tea, which traders took to the other provinces of China (and beyond) along the 'Tea-Horse Road'. Wikipedia agrees, so it must be true!

The game's board shows the town and market of Pu'er, the main source of the tea, with five provinces – linked by the Tea-Horse Road – running from the bottom right corner around to the top left. The town takes up a fair amount of space, since the buildings shown here are where players put their worker pawns to select their actions for the turn. Workers will also go into the provinces, as traders, along with some of the players' other pieces.

Each player gets a set of wooden pieces in their chosen colour: backpack wearing workers, a horse (Wikipedia suggests that, historically, the tea traders used mules and Tibetan ponies), tea house, two trading posts and various other markers. There are a couple of neutral pieces plus cardboard coins and other markers. Players start with three workers and some cash, depending on their position in the turn order – decided at random to begin with.

In the first part of each round, players take it in turns to place an available worker until they've all been allocated. There are several spaces in each building in the town, each marked with its cost – obviously, players will take the cheapest first. However, there is an auction element to placing workers in the buildings. If you have a pawn on one of the two lowest positions, you get it back if you are over-bid (and can then re-deploy it). Workers on the three high bids stay where they're put. Thus, several players can take the same action in a round and there is the occasional opportunity to get an action on the cheap. As it's taken me some time to learn, if you really want an action, the optimum position is the cheapest that can't be sent packing.

The most obvious action is to get another worker from stock. Having more workers to take more actions is clearly a good idea and you need workers to send to the provinces as traders too. However, I'm not sure that you need to get all

PJ, adv.) have mutual cause as neither stood down over Belle.

Eric de Miabeille (Sabre, Seconds EdSS & TC, adv.) and Frele d'Acier (Sabre, Seconds JA & DS) have mutual cause for being in enemy regiments.

Devlin Carnate (Rapier, adv.) has cause with Etienne Brule (Rapier, 1 rests) for pinching Belle.

“adv.” shows who (if anyone) has the advantage in Expertise: his first duelling sequence need only contain six actions.

Duels held over until June

Maurice Essai Deux versus “the Hokey Cokey”.

All duels (including any to be voted on) must be fought next month unless held over due to one or other duellist being at the Front. Orders conditional on a challenge being voted cause are acceptable.

New Characters

Chris Boote gets the Second son of a very wealthy Marquis: Init SL 8; Cash 750; MA 6; EC 3 (X1).

Ray Vahey gets the First son of an Impoverished Knight: Init SL 7; Cash 44; MA 1; EC 6 (X2).

Mark Cowper gets the First son of a wealthy Baron: Init SL 8; Cash 550; MA 4; EC 4 (X3).

Rob Pinkerton gets the Second son of a well-to-do Gentleman: Init SL 4; Cash 250; MA 5; EC 2 (BdLS Bernard de Lur-Saluces).

Tables

Other Appointments

King's Escort: Ensign N	Captain N
Cardinal's Escort: Ensign N	Captain N
Aides: to Crown Prince N	to Field Marshal __
Provincial Military Governors: N/N/N/N/N	
City Military Governor N	Adjutant-General N
Inspectors-General: of Cavalry N	of Infantry AV
Commissioner of Public Safety ROS	
Chancellor of the Exchequer AdL	Minister of Justice N
Minister of War UXB	Minister of State DC

Shows who holds appointments outside military units:

ID for Characters, N for NPC, __ for vacant, CPS for additional posts held by the CPS.

that real life must take priority. You are very welcome to re-join us any time you want to.

Notes

The *En Garde!* rules are available to LPBS players at a reduced rate: see any month's Points Arising web page at www.pevans.co.uk/LPBS.

There's a Yahoo! group for *En Garde!* players that provides a forum for players of different games to swap stories and ideas. Sign up and get talking at: <http://games.groups.yahoo.com/group/EnGardePlayers/>

Announcements

Jacques Shitacks asks NPC Minister of Justice to resign

Jacques Shitacks applies for Minister without Portfolio

Reminders: It is worth sending orders in even if they're a day or two late: I may be able to action the orders and should be able to use any press. It also reassures me you're still there.

Orders (and press) should be e-mailed to lpbsorders@pevans.co.uk – you'll get an automated reply when your message arrives in my mailbox. Please give your name and your character's name and specify actions in full (since it's without your character sheet). If you want queries answered before the deadline, e-mail LPBS@pevans.co.uk instead.

Jacques Shitacks applies for Minister of Justice

Maurice Fluff-Bunny asks NPC Captain 4 of 13th Fusiliers to resign

Duels

Results of April's duels

Arsène Est didn't turn up to fight Xavier Self Zeffort and lost SPs.

Frele d'Acier declined to meet Terence Cuckpowder as he was under half Endurance.

Terence Cuckpowder (with RdM, gains 1 Exp) killed his enemy Yves Vrai Bretheauteque (with EB).

Terence Cuckpowder (with RdM, gains 1 Exp) beat his enemy Etienne Brule.

Maurice Fluff-Bunny (with PJ, gains 1 Exp) beat Chopine Camus (with DS).

Frele d'Acier declined to meet Maurice Fluff-Bunny as he was under half Endurance.

Jacques As (with FdA & DS, gains 1 Exp) beat Maurice Fluff-Bunny (with PJ).

To be settled next month:

Etienne Brule (Rapier, 4 rests) and Terence Cuckpowder (Sabre, adv.) have mutual cause for being in enemy regiments.

Frele d'Acier (Sabre, Seconds JA & DS, 2 rests) and Terence Cuckpowder (Sabre, adv.) have mutual cause for being in enemy regiments.

Etienne Brule (Rapier, 1 rests) and Maurice Fluff-Bunny (Sabre, Seconds

seven workers into play. Players may retrieve workers from the provinces to use in the town. This needs some thought, though, as there is a cost to moving workers – especially into the further provinces.

The second most obvious action is to move your horse. The horses represent how far each player has connections along the Tea-Horse road. They start in the first province, Yunnan itself, and players can only move their traders (workers) to provinces their horse has reached. In order to move traders, players also need border passes. The number of border passes they have is shown by the position of each player's marker on a track and these can be used every round. Moving their marker along the track is another action/building available to players.

To get to more distant and more valuable provinces, players need to use both these actions: increasing the range and the mobility of their traders. I prefer moving my horse first, but it's not a disaster to do them the other way round.



Yunnan on display at Spiel '13

In addition, players will get points at the end of the game according to how far along the border pass track their marker is, so there's a long-term incentive as well as the immediate gain. The same is true of the track next to it, representing players' influence. Increasing their influence is another action/building. Having more influence allows a player to push other player's traders backwards, but also makes them a target for the Inspector (of which more later).

Almost last, the Construction building allows the player to take one of their non-worker pieces (trading post, tea house and bridge) from stock and have it available to use. Workers can also be placed in the Market, whence they may travel to the provinces as traders.

There is one last building (though it's the first to be resolved): the bank. Money is tight in this game and the bank offers a way of getting cash. There is no cost for putting a worker in the bank, but all the players' other workers must go to the Market – even if they've already been placed in buildings. The amount of cash depends on the amount all players are spending that turn. This is a rather neat mechanism that allows players to get a heap of cash, if they time their visit to the bank just right.

Once everybody has placed all their workers, the effects of the buildings are resolved. The turn order is then reversed and players get to move their traders. Each player does all their movement before the next player gets their turn and is restricted in a number of ways. First, they can't move any trader further along the road than their horse. Second, they need a border pass for each border crossed by a pawn. Thus, the two passes everybody starts with allow them to move one pawn two provinces or two pawns one each.

Third, once they've finished moving, they must have a continuous chain of traders (or trading posts) back to the Pu'er market. Trading posts act like immobile traders, but produce a lower income and are not vulnerable to the Inspector or other players. The other thing a player can do when they've finished moving their traders is bump another player's trader back a province – if they have higher influence than that player. The competition in the tea trade is something fierce!

As part of movement, players can also deploy any trading posts, tea houses and bridges they have available. Trading posts I've already explained, while tea houses bring in points at the end of the game. Each player only has one tea house, a province can contain only one and they're worth more points the further from Pu'er they are. Bridges are much more interesting: they allow players to establish shortcuts which bypass one or two provinces along the road. They can only be built between provinces where the player has traders, so you still have to get there. However, once built they are very useful in getting your traders further along the road and reducing the number you need for a continuous chain.

let me quote “I would defend my honour with my life, cur. Will you even show your face to protect yours?” Let us see your honour. You have been found to be a liar, now do the honourable thing: throw yourself onto your sword.

† The Hokey Cokey

To the good 1st Major of GDMD
Sir, you have been doing a good job,
and perhaps you should consider
staying. † TC

Poetry Corner

(All signed poetry submissions gain their author at least 1 SP)

Found scratched on a privvy wall
near Bothwell's.

They seek him here,
They seek him there,
The Sheikh's Lackeys
Seek him everywhere,
The cursed, elusive Hokey Cokey.
† The Privvy Poet

Curiouser and curiouser,
One never sees that Cuirassier
When visiting the field of honour.
It seems that Gaviscon
Is Gavis gone!
† BCdT, Grand Duke Max's Dragons

Points Arising

Next deadline is 14th Nov 2014

The NPC Minister of Justice will quit at the end of May. Anyone wishing to apply for the job should do so with next turn's orders.

Speaking of which, the post of Minister of State will also be vacant at the end of May, due to the... um, retirement of Devlin Carnate. Anyone wishing to apply for the job should do so with next turn's orders.

MED has been voted cause for his challenge to “the Hokey Cokey”. Anyone who wants to fight MED as the Hokey Cokey should let me know.

I had no orders from the following and they suffered the consequences:
AE Arsène Est (Ray Vahey) has
NMR'd. Total now 2 and is sent to a
Frontier regiment

LL Lothario Lovelace (Geoff Bowers)
has NMR'd. Total now 1
TIM Tomas le Matelot (Tim Skinner)
has NMR'd. Total now 1

AFD (Gerald Udowiczenko) and WP (Pam Udowiczenko) were floated as both are “in France with poor internet access.” Ouch!

Welcome

Rob Pinkerton joins us from Canada. Welcome to LPBS, Rob, and enjoy the game. Rob is new to *En Garde!*, so this will be a voyage of discovery.

Farewell

Bruno Giordan bows out as “Life is rather full at the moment what with work, caring for an old lady we know and all the usual stuff.” Sorry to lose you, Bruno, but I quite understand

To RdM

Sir,

I understand you are after the position of Aide to a General.

I am happy to offer you the position. By the way can you manage to talk with a lisp? It would help you fit in with the rest of my staff.

† Bdr-General EM2

To the Sinister Hokey Cokey

Sir – I fail to see how you come by these slanderous conclusions. I have never supported the madness that was the Evil Sheik or been complicit in his attempts to bring down His Glorious Majesty.

As you hide behind your anonymity I cannot see how I can answer your baseless accusations – to that end I challenge whoever you are and fully expect these false rumours to stop.

God save the King!

Yours Expectantly,

† Lt Col D Sinistre – GDMG

To all in Paris

How safe is your King?

The Al-Abowt's Avengers have sprung up.

The Royal Foot Guards are compromised by Lt. Colonel Amant de Au.

Two battalions of The King's Musketeers are overseas playing at Follow that Camel.

Even worse they have with them Maurice Essai Deux and Dick D'Asterdly known camel worshipers.

We must be proactive and purge the city of the camel taint.

† The Hokey Cokey

Rob d'Masses

In response to your estimation of the Dragoon Guards' duelling skills. First of all I would like to thank you for your kind comments with regard to our bravery, please share them with your Colonel who regularly fails to attend duels.

I think Top Cat Cuckpowder had a rather sore victory last outing. I trust Lucy Fur is still looking for satisfaction?

With regard to your victories with the sabre – bravo! Pity that as cavalry officers your riding skills fail to match those. The last horse race in Paris was won by Yves Vrai Bretheauteque the Dragoon Guard commander, 2nd was myself and 3rd was Chopine Camus. Where were the Queer Old Codgers?

With regard to our education: that can be arranged.

Kind regards,

† Frele d'Acier

The Voice of the AAA? Sounds like a call for all of them to be visiting the AA.

† Cuckpowder

To Lt. Colonel Amant de Au

Let me quote "No one in Paris was prepared for the utter madness of Sheikh Yadik Al-Abowt."

His madness was apparent to those not associated with him throughout 1666. Yet, even in Nov 1666, you attended SYAA's wake to Ali Al-Headsoff and were admitted to his entourage. You, like Maurice Essai Deux, show an amazing capacity for deception and dishonesty and wrap it in the mantle of a gentleman. Again



Playing *Yunnan* at MidCon in 2013

After all the players' movement, the Inspector arrives. He visits the province where the highest value of tea is being traded this turn. That is, where the sum of all players' income is greatest. Income comes from traders and trading posts and their value is higher the further the province is from Pu'er. The Inspector then banishes one trader, belonging to the player with the most influence, back to Pu'er. This provides some interesting manoeuvring during movement as players try to work where everybody's traders will be and thus which province the Inspector will visit. The way of avoiding this is to build your tea house: you're safe from the Inspector in the province with your tea house!

Players' income is now marked on the track around the edge of the board and this determines the order of play for next round (highest income goes first). Then, in order, players decide how much of their income to take as cash and how much to turn into points (marked by a differently-shaped marker on the same track). This is a clever mechanism. Although players will generally take cash early in the game and points in the last couple of turns, the critical decision is when to switch. Too early and you're out of cash while your opponents have developed their trading network further. Too late and they'll simply have more points!

One thing I've not mentioned yet is the stack of 'presents' in each province after the first one. While there are any presents left, they are dished out to players who have a trader in the province at the end of a round. Each present is worth a few points at the end of the game, so the odd one doesn't make much difference. However, having substantially more than your opponents is very useful. Thus the presents are an incentive to move quickly along the Tea-Horse Road and to keep up with the other players.

The game ends when somebody hits the 80-point mark. Play continues to the end of the round and final points (for cash, tea houses, influence and border passes) are added. As usual, the player with the most points wins and is allowed to feel smug. (That last bit may just be me.)

There's one advanced rule ("recommended after your first game"), which allows players to go into the red when bidding. They lose points for the money they don't have and more points the earlier in the game they do this (of course, it's more useful early in the game). My experience is that it's not used much as the cost is pretty high. However, it's a useful way of getting the odd coin that you're short of and it does add an extra element to the calculations of what other players are going to bid for.

Yunnan is not a game to set the world on fire, though it does have some interesting mechanisms. It is a solid medium-weight game that provides players with some interesting decisions and trade-offs over 90 minutes of entertaining play. There's scope to put one over your opponents (an unexpected dash to the bank being the obvious gambit) and the opportunity to damage their plans. However, players must balance what they're doing to expand their trading profitably and, crucially, get their timing right to rack up a pile of points in the end-game.

I've had a lot of fun with *Yunnan*, as have others at the Swiggers games club. I give it 8/10 on my highly subjective scale and would like to thank Roman Mathar of Argentum Verlag for providing a review copy.

Yunnan was designed by Aaron Haag and published (in Germany) by Argentum (in several languages). It is a strategy board game for 3-5 players, aged 12+, and takes about 90 minutes to play.

This review was first published in *Counter* 65, June 2014.

The Rogues and Vagabonds club is to take a short break ... time to go a-wandering...

† AdL

Ladies and Gentlemen,
Ophelia and I are delighted to continue hosting the 'Académie de Danse' in the Fleur De Lys ballroom during the 3rd week of each month. Our offer extends to all those of SL 12 or higher with a suitable mistress to come and learn from their betters. All costs will be paid for those of SL 15 or higher, in appreciation of their efforts to impart their dance insights. In addition, a prize of 50 crowns will be offered to the couple teaching the most interesting new dance.

For May 1667, we have decided to concentrate our efforts on the Gigue, a lively baroque dance refining techniques crudely suggested by the British jig.

As ever, applications from those of a lower social standing, but with a burning desire to learn, will be considered.

† Sir Voulo Vault, Major RFG/Gds
Brigade Maj.

Personal

Lord Percy Percy says, as fashion is tending towards the beige, Jacques As wears very fashionable clothing.

I looked at Was Nae Me from a safe distance, and he does seem to be walking in a rather stiff-legged fashion.

† Plume de Votre Tante et ne pas de
moi

To Maurice Essai Deux

Let me quote: "I am hard pressed to answer your slander." That is because it is not slander. You did attend SYAA's wake to Ali Al-Headsoff and you were admitted to his gathering in Nov 1666. In short, the label fits. In addition, your mendacity is incredulous. [sic]

Again, let me quote: "I am now in the process of interrogating the enemy officer I captured for King and Country at the front." The only officer mentioned with you was your CO and your comments about him show a lack of decorum. You show the same disrespect for proper authority that the sheikh displayed.

I'm afraid your protestations of innocence are false and your desire to duel is an attempt to silence the truth.

† The Hokey Cokey

Devlin Carnate has inklings of evil about him.

To: All true patriots and gentlemen of France.

The time has come to depose this corrupt government with its swindlers, thieves and murderers. We call upon you to rise up against the tyrants, put to the sword the likes of Carnate, Xavier-Beauregard, O'Shea, Moutarde, de Lieu, Shapmes, Humble, Zmerchant, Nae Me, D'Asterdly and all the other villains. Remember The Emperor will reward his loyal followers and supporters. He will not forget, He will avenge ... He is coming.

Voice of the Al-Abowt's Avengers
Wear the Fist, Show the Faith

Frontier regiment 2 is backed up by the first battalion of the King's Musketeers and holds its own. KM Lt-Col Was Nae Me bosses his men around effectively enough to earn a Mention ("A good boss") and plunders nearly 500 crowns worth of goodies. (Brevet) Subaltern Maurice Essai Deux sees his name in the Despatches, too ("A *brevet* Subaltern?"), but gets no loot.

The big losers are Frontier regiment 4 on the shoreline as some defenders sneak past them in small boats and attack from the rear. Luckily, the second battalion of the Picardy Musketeers are on hand to see them off again. Major Arnaud Surfinmaise, commanding, receives a Mention in Despatches ("excellent about-face!"), as does QOC Captain Rob d'Masses. He survives a close encounter with the attackers and their scimitars thanks to his solid cuirass. ❖

Press

Announcements

OK fellahs, after a hard month's carousin' it's time to go an' do a bit 'o enemy bashin'.

Accordingly, the entire DG is off for a bit of a runaround next month.

Make yer plans accordingly.

Oops! Shame about that duel.

† Le Roi

Despatches from the Front

Dear Father (Baron Hardup),
I am in Africa. It's very hot. We seem to be hunting down some enemies of France known locally as IS; some sort of sect associated with the late President. Nasty fellows, big beards, even bigger curvy swords and flared pantaloons. Anyway, the boys saved me from total disaster when a part of the wall knocked me off my horse and gave me a splendid Fez (a sort of local hat) for your next play 'Aladdin and the genie of the Lamp' which is in the parcel.

I tried to wash out the bloodstains, but a bit of beetroot water and an

overnight soak, and who would ever know. I have also managed to sell a few curvy swords which should see the wolves and bailiffs from the door for now. I will try and get you some nice slippers with curly toes and a jewelled waistcoat.

Your loving son, † Henri

Social

Dear Comrades in Arms of the Glorious Fighting Thirteenth,
There will be a Pre-Summer Campaign briefing and training exercise carried out in Week 3 of May. We shall commence with the military aspects of the regiment before then proceeding to an informal drinks session at my club, Blue Gables, to raise a flagon or two to our future successes and to toast the health of our, presently, 'overseas friend' and remember the tragic murder of our previous 'overseas friend'. Mistresses are permitted and as the Commanding Officer of our fine regiment it is my pleasure to inform you that all carousal costs are being 'taken care of' by our 'overseas friend'.

Games Events

1st November is the next Pasteboard and Plastic event. Held at the Scout Hut in Saltdean (Sussex), it's a "A friendly, cheap, board games day." The event starts at 10 and entry is £4. As it's mainly local gamers, I suggest getting in touch beforehand rather than just turning up. There's an online Yahoo! group to support the event: uk.groups.yahoo.com/neo/groups/pasteboardandplastic

Three weeks after Spiel, the weekend of 7th-9th November, is time for **MidCon**, which makes it a great opportunity to play some of the new games that people have brought back from Essen. It's one of my favourite conventions, held in a comfortable hotel in the centre of Derby (right next to the railway station). Three days of gaming with the odd organised event – notably a quiz on Saturday night. T'committee lays on real ale, not normally available in the hotel bar, but essential gamer fuel (or is that just me?). On top of this, there are a surprising number of good places to eat within walking distance. All in all, an excellent (long) weekend. For more information, see www.midcon.org.uk or the BGG Guild www.boardgamegeek.com/guild/1872

This box concentrates on events I expect to attend.

Swiggers: games club that meets every Wednesday evening, usually upstairs at The Shipwright's Arms, 88 Tooley Street, London SE1 2TF (a few minutes' walk from London Bridge station). For more info, see www.pevans.co.uk/Swiggers

Games Games Games Days: from noon(-ish) on the second Saturday of most months at the Allsop Arms (137 Gloucester Place, London NW1 5AL). The pub has an extensive menu as well as good beer and is convenient for Baker Street and Bond Street Tubes as well as Marylebone station.

UK Games Expo: 29th-31st May 2015 in the Hilton Metropole at the NEC. This is a public event that showcases games of all sorts with traders, demos and participation games plus guests. For gamers there are lots of tournaments and open gaming. For details see www.ukgamesexpo.co.uk

Spiel: the board games event of the year. October 2015, at the Messe (Exhibition Centre) in Essen. Contact Friedhelm Merz Verlag, Postfach 210250, Bonn, 53157 Germany or see www.merz-verlag-en.com

MidCon: 7th-9th November 2014 at the Hallmark Hotel in Derby. MidCon is a friendly board games convention in a decent hotel. See www.midcon.org.uk.

For more extensive information on UK board games events, try the following.

The Labyrinth: <http://homepage.ntlworld.com/the-labyrinth/games/>

The Queen's Lane Advertiser: <http://www.boardgamers.org.uk/qla.php>

Fictionary Dictionary

Round 10

Scores from round 9

Points are spread fairly widely this time, but Andrew Kendall stretches his lead a fraction. Tim Macaire is the man in second place, scoring just a point less.

The other top scorer is Nik Luker, but it looks too late for this to make much difference. Brad Martin is still in third place, but Colin Bruce and Alex Everard close the gap.

Just the last round of votes to go and we'll have a winner.

Round 10 definitions

The proposals are below. All you have to do is let me know your favourites.

Ytterbite

1 (Pronounced: eater-bee-tee) The Ytterbite is a very cold, slow moving river between Belgium and France. Its name is used by the Meteorological Office to describe a slow moving cold weather front.

2 A mineral.

3 Skin rash or injury known in Devon, caused by fondling otters. (NB Local pronunciation of otters applies.)

4 A dance peculiar to vampires. Similar to the Jitterbug.

5 A recursive storage format which was technically elegant but practically useless, until someone happens to invent a hard-disk which can be expanded at any given point. (ie 'Iterative Byte', with a bit of playful

Player	This round	Total
Paul Appleby	0	1
Chris Baylis	2	16
Howard Bishop	0	2
Bob Bost	0	3
Colin Bruce	3	19
Andrew Burgess	0	15
Mike Dommett	2	16
Alex Everard	3	19
Mark Farrell	0	7
William Hay	3	11
Pete Holland	0	10
Andrew Kendall	4	31
Nik Luker	4	14
Tim Macaire	3	26
Brad Martin	1	21
Graeme Morris	0	18
Jonathan Palfrey	0	2
Chris Rudram	0	0
Matthew Shepherd	0	0
Gerald Udowiczenko	0	0
Pam Udowiczenko	1	14
Ray Vahey	0	6

spoonerism. Geeks don't get out much.)

6 A sign of true love among dragons.

7 Retaliation by the "biter-bit".

them this month's iron men – but only Jacques invests in Arms this month. Pierre Jambon and Voulo Vault practise rapier for the third time, as does Xavier Self Zeffort for his second week. Richard Shapmes manages one week's rapier practice. Dexter Sinistre and Uther Xavier-Beauregard practise sabre for the third time. Kidder de Margaux puts in his second week of sabre practice, as do Bonne Chance de Tres, Chopine Camus and Jacques As. There's a sabre for Eric de Miabeille to practise with as well. Amant d'Au completes a third week practising dagger. Gaz Moutarde pops in for a week with his cutlass. And Monty Carlo's third week practising with a two-handed sword is also the first week for Bill de Zmerchant.

There are two subjects for discussion around Paris in this last week of April. The first is the fresh crop of clenched fists daubed on the walls of buildings around the city – notably the RFG's barracks and the Ministry of State. The slogans "He is coming" and "He will avenge" also make several appearances. Rumour has it that the CPS's boys have hauled in several people for questioning, including the swarthy Mussulmen that Armand de Luce has about him these days. Nobody can work out whether there is any connection to Devlin Carnate. Rumour has it that the Minister of State was hauled out of his residence by members of the King's Escort. He is allegedly being questioned in the Bastille either about the avenger propaganda or for lèse-majesté in promoting himself on a par with the King!

The last hurrah!

Having scouted the way last month, New Lieutenant-Colonel Gruaud LaRose welcomes the whole of his regiment to the North African coast. Getting their mounts ashore quickly, the Princess Louisa Light Dragoons join the besieging forces. They see off several attempts to relieve the siege by local forces, earning Lt-Col LaRose a substantial Mention in Despatches ("see him chase the Arabs!"). He adds over 500 crowns to his personal coffers in loot.

Despite this, the Frontier regiments have difficulty maintaining the siege. Third regiment is surprised by a mine that blows a hole in their ramparts. A sallying force of defenders charges towards the gap. But into it springs Major Henri Hardup. "Hooray!" he cries, waving his sword at the enemy and the other arm frantically at his command, the third battalion of the King's Musketeers. The gap is plugged by the Musketeers, who hold off the attackers with some well-directed volleys. Then Lt-Col René de Gaviscon's squadron of the Archduke Leopold Cuirassiers charges round the fortifications and routs the Arab force. Henri's men compete to hoist him onto their shoulders. "Hooray!" he shouts, waving in triumph. Then he slips, as the men continue to jostle each other, falls onto a broken pike discarded by the Frontier troops and expires. RIP.

René de Gaviscon receives a fulsome Mention in Despatches ("Chaaarge!") and pockets well over 500 crowns of booty. CPC Lt-Col Dick D'Asterdly is also attached to the third Frontier regiment and manages to remain anonymous. Hooray Henri Hardup gets a military funeral.

Angelina, looking rather tousled after being “taken to heaven”!), Pierre Cardigan (and Edna) and Pierre le Sang (plus Guinevere). Eric de Miabeille and Anna have Bothwell’s to themselves again. The quiet of the club is disturbed by some noises from outside. These are made by Bill de Zmerchant as the man he expected to be running the Académie de Danse, Amant d’Au, is not in evidence.

Coeur De Lion and Ada are in Red Phillips again. And we can guess where Euria Humble is. Jacques le Franc fails in his courting, but Etienne Brule is successful. Something that will annoy Devlin Carnate.

Egon Mad 2 and Jacques de Gain put in their third week of rapier practice, while it’s Pierre Jambon’s second week. Dexter Sinistre and Uther Xavier-Beauregard practise sabre for the second time, joined by Kidder de Margaux and Tourtière Mangetout for their first session. There are second weeks for Amant d’Au on dagger and Monty Carlo on two-hander as well.

Social events have dried up at the end of April. Except for Eglise de Sant-Suplice and Frances Toadying to Gar de Lieu and Maggie once more. Their fellow occupants of the Fleur are Armand de Luce, Ali Vouzon (and Angelina – beginning to feel she’s being taken for granted), Jacques Shitacks (and Madelaine), Pierre Cardigan (and Edna) and Pierre le Sang (plus Guinevere).

Things have changed in Bothwell’s, though, as several members turn up for the last week. Etienne Brule brings his new conquest, Belle Epoque. Frele d’Acier escorts Freda. Jean Jeanie has the company of Lotte, while Jacques le Franc has Laura de Land on his arm for the first time this month. Terence Cuckpowder and Lucy are last through the door, attracting abuse from the gaming tables where Etienne and Frele are to be found. Etienne bets big, winning two, losing one and cutting the fourth of his wagers. This leaves him with a small profit. By contrast, Frele makes one bet at the house minimum and wins it.

Coeur De Lion and Ada are in Red Phillips once more. Euria Humble is at his post. Hitting the Bawdyhouses are Maurice Fluff-Bunny, Pepé Nicole and Rick O’Shea, all getting their oats. There’s the sound of musketfire from the 53rd Fusiliers’ barracks as Tourtière Mangetout searches for his best shots to form a sharpshooter company.

It’s four weeks rapier practice for Egon Mad 2 and Jacques de Gain, making



Zonule

1 The alchemist’s “seed of life”, which, when planted in the right conditions, grows into an animal companion.

2 The reddish area of skin surrounding a ripe zit.

3 Code-word used in pharmacies. Try asking the assistant in a confident voice for “Zonule”, while staring meaningfully at the behind-the-counter (and embarrassingly-named) preparation that you really want.

4 This is the regulating of industrial buildings on the outskirts of major European towns.

5 Ghastly ‘hip’ neologistic term for the point where two regions of electronic media meet. Should never be used by anyone above the age of 18, especially by desperate politicians.

6 Cross between a Zebra and a mule.

7 A planet mentioned in *The Hitchhiker’s Guide to the Galaxy*.

Send your votes (just two numbers) to Pevans at 180 Aylsham Drive, UXBRIDGE UB10 8UF or to TWJO@pevans.co.uk by 14th November 2014

What’s this about?

This game is open to all readers and I guess most of you will have come across it. Each issue I will put up a couple of obscure words. Anybody who wants to participate writes in with fictional definitions of the words. (For example: “Geranium: a ceremonial dagger used by Aztec priests for human sacrifice.”) I publish these, anonymously. All

readers (not just those who contributed) vote for their favourite definition (a vote for your own definition will be ignored).

Players score points for the number of people who choose their definition. We’ll run this for 10 issues and the winner will be whoever has the most points at the end.

Medstead and Four Marks

Railway Rivals game 10 - Turn 8

Quite an even sharing of the points from the races this turn. TXR then builds west, CoWS builds to the coast and ARB heads south west.

Races					Scores				
					JAB	ARB	CoWS	TXR	SNS
10	JC	Arizona	3S	Lubbock	10	20			
11	10C	Raton	5H	Beaumont	5	10 -2	10 -2		5 +4
12	QC	Arizona	7D	Muskogee		20 -3	+1		
13	2D	Bartlesville	QH	Dallas		0 +2 -5	10	20 -6	0 +5
14	QD	Denison	7S	Del Rio	10 +1		10 -9	0 +8	10
15	4D	Oklahoma City	3C	Clovis		10 -1	20-4		
16	JS	Mexico	9D	Lawton			10 +3	20	0 -3
17	10S	Laredo	2H	Houston			5 -1	5	20 +1
18	8H	Waco	5C	El Paso	20 -5			+5	
TOTAL					41	51	53	52	42

ERP = Exchange of Running Powers; JR = Joint Run

Builds and Points

Jacobahn (JAB)

Mark Cowper (Black)

Builds: None

Points: 104 +1 +41 = **146**

Andrew's Railway Business (ARB)

Andrew Burgess (Blue)

Builds: (A66) - X14 - Roswell - T13
(7 + 1 to JAB)

Points: 49 -8 +1 +51 = **93**

Carriages or Wagon Systems (CoWS)

Paul Evans (Red)

Builds: (H32) - D34 - D35 (5 + 1 to SNS)

(B81) - E83 (3 + 1 to SNS)

Points: 120 -10 +53 = **163**

Texas Rock Crusher Railway (TXR)

Jonathan Palfrey (Green)

Builds: (Altus) - B73 - Amarillo
(Texarkana) - V44 (9)

Points: 96 -9 +52 = **139**

Stars N Stripes (SNS)

Gerald Udowiczzenko (Brown)

Builds: (E82) - E81 (1 + 1 to ARB)

Points: 52 +2 -2 +42 = **94**

Bill de Zmerchant (and Mary Huana), Jacques Shitacks (and Madelaine), Pierre Cardigan (and Edna) and Pierre le Sang (plus Guinevere). Red Phillips finally gets a visitor: Coeur De Lion brings Ada for a week out.

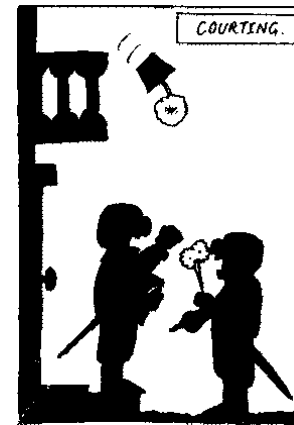

Egon Mad 2, Jacques de Gaulle, Pepé Nicole and Voulo Vault continue their rapier practice. Joining them are Pierre Jambon and Xavier Self Zeffort. Others take up the sabre for the week: Bonne Chance de Tres, Chopine Camus, Dexter Sinistre, Jacques As and Uther Xavier-Beauregard. Dagger is the weapon of choice for Amant d'Au's practice, while Monty Carlo goes to the opposite end of the spectrum, working out with a two-handed sword.

Kidder de Margaux practices something else as he visits the Bawdyhouses for wine and women. No such luck for Euria Humble, on the doorstep that he's made his own. Nor for Maurice Fluff-Bunny or Etienne Brule. These two meet outside the same young lady's door and neither will allow the other to

proceed. That's another duel.

Dancing the night away

Voulo Vault's Académie de Danse continues in its regular week 3 slot with the Gavotte being the featured dance. Voulo and Ophelia Derriere welcome couples to the Fleur's dance floor. Rick O'Shea is thus expelled when he turns up on his own. At the top of the dancing list are Chopine Camus and Sheila. Frele d'Acier partners Freda. Gaz Moutarde is with Anne and demonstrates a Welsh clog-dancing technique, the "Toby". This involves a Cossack-style, kicking squat that ends with a high leap over a broom to snuff out a lit candle with his feet. It's fun, but is it dance? Jacques As brings Thomasina and they introduce the "Garrotte", where the dancing couple hold each end of a short cord. Jean Jeanie escorts Lotte. Jacques Shitacks has Madelaine on his arm. Terence Cuckpowder squires Lucy and, of course, exchanges challenges with Frele. After some consideration, Voulo awards the prize for best new dance to Gaz for his Welsh clogging.

Bonne Chance de Tres is in Blue Gables with Pet. He has invited the Grand Duke Max Dragoons and their friends for some friendly preparation for the summer campaign ahead. Nominally, this includes some martial exercise "in the yard". In practice, it seems to be more about preparing their guts for the poor fare on campaign by the application of much alcohol. Pepé Nicole, of the 69th Arquebusiers, is one guest. The other is Xavier Self Zeffort, who seems to be doing the rounds of the regiments this month. He brings Lois with him.

Back in the Fleur, Gar and Eglise continue their foursome with Maggie and Frances. Other members in attendance are Armand de Luce, Ali Vouzon (and

Down the Seine without a paddle

Week 2 and it's time for Jacques le Franc's spring boat race. Challenging entrants to paddle a canoe 2 km along the Seine, Jacques is the first to spring into his boat. Whereupon it rolls over and deposits him in the river's murky waters. The big man surfaces, spluttering madly, and hauls himself back into his craft. It's no surprise that one of his fellow Royal Marines is the clear favourite: Gaz Moutarde is the man.

As the six entrants paddle off, Gaz is quick to establish a lead. Behind him is Richard Shapmes, giving the lie to those detractors who expected a General and Minister to bring a minion to do the rowing for him. Despite his cavalry training, Frele d'Acier is in third place, with Jacques close behind him. Terence Cuckpowder and Tourtière Mangetout bring up the rear. On the bank, a small group cheers them on: Ella for Richard, Freda for Frele and Lucy for Terence. Rick O'Shea is also there, cheering for his host, Jacques.

Wielding his paddle effortlessly, Gaz propels himself further into the lead by the halfway mark. Richard remains in second, but some frantic paddling by Frele allows him to catch up. A similar frenzy from Tourtière sees him surge into fourth, while Terence is having trouble keeping a grip on his paddle. So, too, is Jacques, who is only saved from the ignominy of last place by Terence's efforts.

Having established his superiority, Gaz slows his stroke. He maintains an even pace towards the finish line, but is clearly going slower than he was. Frele seems to have tired as he slows, too, but is gradually catching Gaz. The revelation is Richard, who steps up a gear. He paddles like a fury, quickly leaving Frele behind as he surges forwards. With every hundred metres the gap between Richard and Gaz reduces. Gaz suddenly realises the danger as he spots Richard's canoe coming level with 200 metres to go. He digs in, but the momentum is with Richard. He glides half a length ahead and, despite Gaz's efforts, maintains this lead to the finish.

Frele comes in third, several boat-lengths down. Jacques has finally got his act together and catches a clearly tired Tourtière to finish joint fourth, albeit several more lengths behind Frele. While Terence has lost his paddle and uses his hands to propel his canoe across the line some minutes later.

After their exertions, the competitors (and Rick) and their ladies decamp to Bothwell's for a well-earned glass of something. This is when Frele and Terence renew their regimental dispute, given extra spice by their relative performances in the race. However, Terence has support this time. His regimental commander, Eric de Miabeille, is in Bothwell's with Anna and joins in the exchanges. Jean Jeanie and Lotte have another table, but stay away from the sweaty canoeists.

Back in the Fleur, Eglise de Sant-Suplice continues to Toady to Gar de Lieu, with their respective mistresses in attendance. Other members in the club are Armand de Luce, Ali Vouzon (and Angelina, enjoying being taken for drinkies),

Next turn's races

Number	From	To
19	5S San Antonio	6H Lufkin
20	9S Corpus Christi	5D Oklahoma City
21	QS Mexico	KC Colorado
22	9H Fort Worth	3D Enid
23	KH Louisiana	9C Santa Fe
24	JD Wichita Falls	AC Daliart
25	3H Houston	8D Altus
26	2S San Angelo	6C El Paso

GM Notes

Each player may enter up to 6 out of 9 or 5 out of 8 races. Held over races don't count towards these limits. Some races may require Joint Runs or Exchange of Running Powers.

Yellow (HAT's) track remains in place and can be used on regular payment. Payments are made to HAT but not recorded on HAT's total.

Some people were building towards the 'card' in states, glad we corrected this.

After the races each player may build up to 8 build points (including known payments to rivals).

Send your orders to Mike Dommett, 119 Victoria Road, Alton GU34 2DD or by e-mail to mike_dommett@yahoo.co.uk by 7th November 2014

Close to Critical

Star Trader game 7 – Turn 8

"A Hunter pod?"

"Yes please."

The Trader lifted his head. "Sure? Nothing more?"

"Yes, that's all we want."

At Gamma Leporis AVERY & SONS bought 8 Alloys for 3 HTs each and gained a Contractorship.

Epsilon Eridani was quiet

At Tau Ceti, apparently forgetting the absence of a Warehouse, AVERY & SONS bought 10 Isotopes for 2 HTs, gained a Dealership and lost the Isotopes again.

SAILCAT sold 4 Alloys for 8 HTs each at Mu Herculis and then sold 6 Isotopes at the same price. After this THE 7 CORPORATION sold 5 on Contracts. AVERY & SONS bought 12 Monopoles for 12 HTs apiece and took their second Contractorship this Quarter.

THE 7 CORPORATION bought 7 Isotopes for 5 HTs each at Sigma Draconis, gaining a Contractorship, and also bought 5 Spice on Contracts.

Beta Hydri saw MARATHON MANIACS selling 6 Alloys at 8 HTs apiece – gaining a Dealership – and SWISS MERCENARY FLEET selling 10 Isotopes for 7 HTs each and a Dealership too. Then COSTA NOSTRA PIZZA sold 6 Monopoles at 16 apiece, winning a Contractorship, and THE 7 CORPORATION sold 5 on Contract to complete the quarter’s trade.

AVERY AND SONS sold their ship, Mawnan, for 90% of list price at Mu Herculis and increased their Political Connections.

SAILCAT sold the Furs at Beta Hydri.

THE 7 CORPORATION laid down a Corco Zeta Hull with A class crew at the Epsilon Eridani shipyards and added Cargo and Augmented Jump pods. The ship is to be named Slave.

MARATHON MANIACS loaded Passengers for Sigma Draconis and bought two Warehouses, one each at Gamma Leporis and Sigma Draconis

SWISS MERCENARY FLEET laid down a new Piccolo Hull in the Tau Ceti shipyards

COSTA NOSTRA PIZZA loaded passengers for Epsilon Eridani and then trudged down to the Federation bankers and repaid their loan. They also landed a ship on Planet at Epsilon Eridani and loaded a Hunter Pod, which will limit the Spaceports it can enter.

Corporation Table

Corporation letter and name	Connections Bus/Crim/Pol	Init ^v Bid	Turn order	Cash Rep'n	Player
A Marathon Maniacs	10 0 0	0	5th	276 30	Andrew Burgess
B Costa Nostra Pizza	5 5 1	0	2nd	58 27	Mark Cowper
C Sailcat	7 0 7	0	4th	887 40	Mike Dyer
D The 7 Corporation	7 4 5	0	6th	164 40	Paul Evans
E Swiss Mercenary Fleet	6 7 0	0	3rd	139 40	Martin Jennings
F Avery & Sons	8 8 1	5	1st	220 38	Prezemek Orwat
N under Initiative Bid means No move received, F indicates the Corp was floated					

Terence is in the Queen’s Own, while Etienne and Frele are both senior members of that regiment’s enemies, the Dragoon Guards. Challenges are exchanged to uphold regimental honour. Skirting the fracas is the last name on the guest list, Uther Xavier-Beauregard, who brings Henrietta Carrotte with him. Etienne’s gambling antics provide light relief for the gathering. Having lost his first three wagers, he cuts the last one in disgust when the bank rolls high. He is left significantly out of pocket.

Jacques’ competitor is Armand de Luce with his latest Rogues and Vagabonds party, also at the Fleur. It isn’t much competition, though. As the theme is “Tramps and Thieves”, Armand is dressed as a gentleman of the road – faded, but expensive, old-fashioned court clothes with the lining showing through slashes in the outer cloth. Jenny Russe, on his arm, is also dressed as a thief – the infamous English bandit Moll Cutpurse. Armand’s only guests are Chopine Camus and Sheila Kiwi, who have not bothered with costumes. Gar de Lieu is in the Fleur, too, admitting Eglise de Sant-Suplice as his Toady. Eglise brings Frances Forrin with him, making a foursome with Gar and Maggie Nifisent. And Pierre Cardigan brings Edna Bucquette to the Fleur for a quiet drink.

Dexter Sinistre has Bothwell’s as the venue for his tête-à-tête with Ava Crisp. Eric de Miabeille and Anna Rexique have the same idea, but the club is big enough for both couples. Monty Carlo and Charlotte de Gaulle have Hunter’s to themselves. New Colonel Maurice Fluff-Bunny is holding a recruiting week for the 13th Fusiliers. Perhaps the large banner over the barrack’s entrance is a bit off-putting. It shows the features of the late Sheikh Yadik Al-Abowt and a clenched fist. Maurice then takes his guests to the Blue Gables, where he presents each of them with a brooch. However, one of his guests is already in the regiment – Pierre Jambon, escorting Violet Bott and telling all and sundry how great the 13th are. While the other, Xavier Self Zeffort (Lois de Low in tow), applied to the 4th Arquebusiers this month. Only Tourtière Mangetout and Sue Briquet are in the club as witnesses and Tourtière is more interested in the “lusty red” in front of him.

Egon Mad 2 is to be found in the gymnasium with his rapier. The same is true of Jacques de Gaulle, Pepé Nicole and Voulo Vault. Will any of them keep it up all month? Talking of keeping it up, Euria Humble is once again camped on a certain young lady’s doorstep. Bill de Zmerchant is at home with his lady friend, while Kidder de Margaux fails to impress the object of his affections.

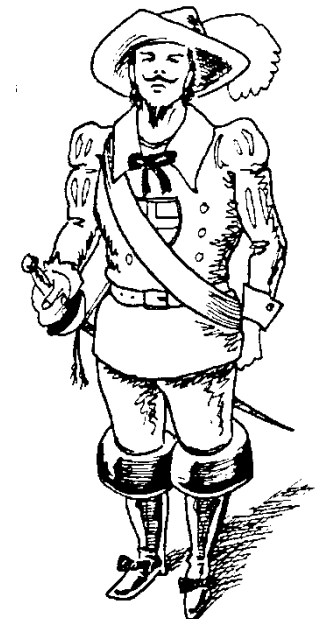

Maurice Fluff-Bunny would like to get rid of the senior Major in his regiment, 13th Fusiliers, so that he can take command. Again, his influence is not up to it and the Major stays on. Instead, Fluff-Bunny buys his way to Colonel and command of the regiment anyway. Pierre Jambon follows in his wake, aiming to become Lieutenant-Colonel. However, his money runs out at Major.

There's no influence from Bonne Chance de Tres to get the senior Major of Grand Duke Max's Dragoons to quit, as he's suggested. Terence Cuckpowder calls in a favour to make sure the Major hangs on.

Eglise de Sant-Suplice has more success. He makes an offer he can't refuse to the junior Major in his regiment, the Crown Prince Cuirassiers. This provides an interesting vacancy for any recent arrival in Paris looking for a senior rank in a cavalry regiment. Shame there aren't any.

Whether the GDMD senior major will resign is a 50:50 bet after Bonne Chance de Tres and Chopine Camus apply some influence to the man. However, the odds of a resignation reduce when Terence Cuckpowder sides with the incumbent. In the end, the result goes Tres's way, opening a position that he quickly buys into.

An unexpected vacancy allows Etienne Brule to buy his way to Colonel of the Dragoon Guards, quickly stepping into Yves Vrai Bretheauteque's shoes.

PLLD Captain Gruaud LaRose doesn't like being on active service on his own. He buys his way to Lt-Colonel. As the new commander of the Princess Louisa Light Dragoons, he orders the rest of the regiment to join him.

Lt-Colonel René de Gaviscon adds his squadron of the Archduke Leopold Cuirassiers to the fray, but Rob d'Masses only commands a troop of the Queen's Own Carabiniers and must volunteer on his own.

Xavier Self Zeffort applies to join the 4th Arquebusiers only to be rejected.

Return of the B&Bs

Social life starts this month with a big party in the Fleur de Lys, hosted by Jacques Shitacks, as a reunion of the Boozers and Bellringers. Jacques admits all comers, but has no escort. Not so, the first man on his guest list, Amant d'Au, who has the company of the lovely Katy Did. Ali Vouzon brings Angelina di Griz - after taking her for a ride in the park. Bonne Chance de Tres is accompanied by Pet Ulante. Coeur De Lion has Ada Andabettoir on his arm. Etienne Brule is the first singleton on the list and he heads straight for the gaming tables. Frele d'Acier brings Freda de Ath. Gaz Moutarde has no companion. Jacques As accompanies Thomasina Tancenjin. Lotte Bottle is on the arm of Jean Jeanie. Jean is eager to hear all about February's service of remembrance, as he missed it. Jacques le Franc doesn't have a '+1'. Pierre le Sang escorts Guinevere d'Arthur. Rick O'Shea is another singleton, counting the crowns he just borrowed from the Shylocks. Richard Shapmes accompanies Ella Fant. Terence Cuckpowder brings Lucy Fur and starts a fight. As is well known by now,

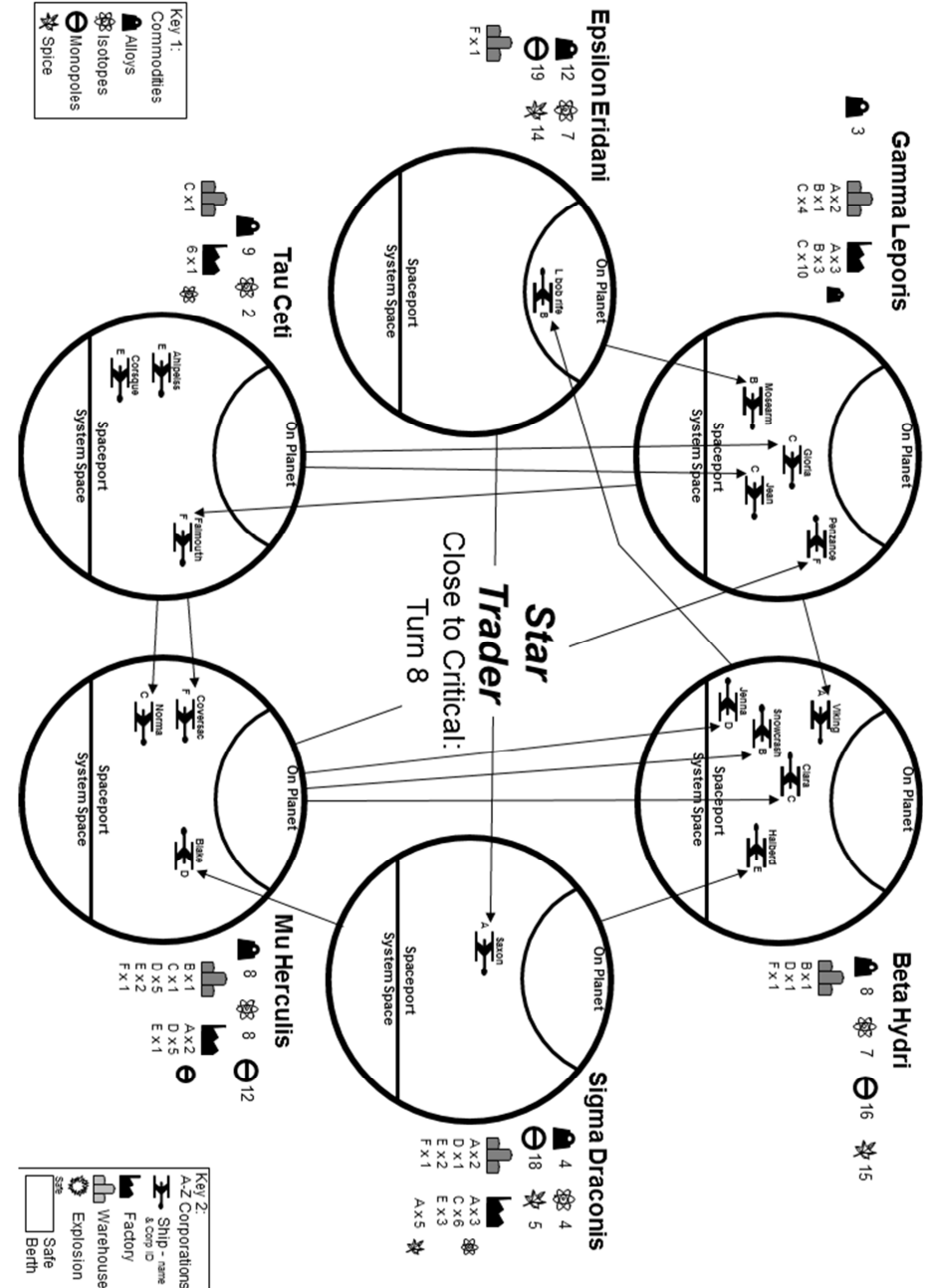

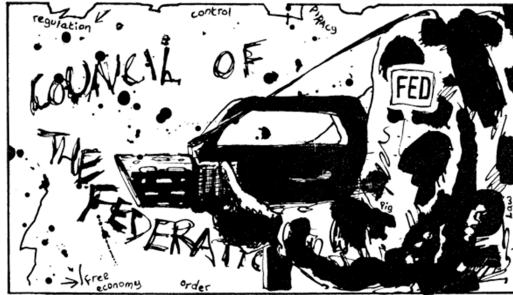

News

COSTA NOSTRA PIZZA took OP 26 from Turn 10.

There were three new News chits this turn. The current chits (new ones in **bold**) are as follows.

Turn 9: B8, P5

Turn 10: C4

Turn 11: **P6**

Turn 12: **B8**

(Chits are identified by the Connection type and level required to see them and disappear/take effect in the News Phase of the turn listed.)

Send your orders to Mike Dommett, 119 Victoria Road, Alton GU34 2DD or by e-mail to mike_dommett@yahoo.co.uk by 7th November 2014

Subscribing to TWJO

TWJO is published on paper and online at www.pevans.co.uk/TWJO (as a PDF document). You can buy or subscribe online or as below.

If you want to play in any (or all) of the games in TWJO, you have two options. You can subscribe to the paper edition, which includes playing in the games. Or you can take the PDF edition and pay the “games only” subscription.

The table on the right shows the costs for the paper edition, including postage (and VAT), depending on where you live.

Paper edition	UK	Europe	World
10-issue (1 year) subscription	£27.00	£45.00	£55.00

The second table on the right shows the games only subscription (including VAT).

Games only	
10-turn (1 year) subscription	£6.00

To subscribe, send your name, address and payment to To Win Just Once, 180 Aylsham Drive, Uxbridge UB10 8UF, UK or TWJO@pevans.co.uk. You can pay by bank transfer (contact me for the company’s bank account details), by UK cheque (payable to Margam Evans Ltd) or by PayPal to TWJO@pevans.co.uk. You can subscribe online at www.pevans.co.uk/TWJO, where you can pay by credit card (via Paypal or Amazon) or Paypal account.

factor. Despite being a Dragoon Guard, Brule uses a rapier for duelling, but his skill with this weapon is much less than Cuckpowder’s with his sabre. Rob d’Masses stands with Cuckpowder again, but Brule’s second, Yves Vrai Bretheauteque, attends only in spirit.

As he’s using a rapier, starting the duel with a furious lunge makes more sense for Brule. Cuckpowder has worked this out too. He parries the lunge and ripostes to draw (a little) blood. Then he jumps out of the way of the cut from Brule’s rapier. Recovering his ground, he attacks with a slash. This strikes hard and Brule concedes the duel before he loses any part of his anatomy.



This brings us to Maurice Fluff-Bunny. He is not happy with a number of Parisians who are of higher social standing than him, but possess not a drop of noble blood. For his duels he wears a cape embroidered with a clenched fist symbol and salutes his opponents with “Vive l’Empereur!” They find this off-putting, which may be the intention. His first meeting is with Chopine Camus, who is noticeably slighter than Fluff-Bunny. And more bandaged. However, he is more skilled with the sabre, which both men wield. They are seconded by colleagues: Pierre Jambon for Fluff-Bunny and Dexter Sinistre for Camus.

Camus’s experience shows as he parries, blocks and jumps, neatly avoiding both blows in Fluff-Bunny’s furious slash. First blood goes to Camus as he attacks with a slash. He then launches in to a furious slash, just as Fluff-Bunny tries a slash. The two slashes strike together. Camus’s expertise lets him land the cut while Fluff-Bunny recovers. A quick block to assess the damage and Fluff-Bunny strikes again, hitting Camus with a further slash. Camus surrenders.

As already noted, Frele d’Acier is unable to attend any duels, leaving Jacques As as Fluff-Bunny’s final adversary. This is again a sabre duel, with Fluff-Bunny disadvantaged by his skill and the gashes from Camus. Acier is well enough to second As, alongside Sinistre, while Jambon remains with Fluff-Bunny.

There is no subtlety this time. They both start with a furious slash and hit with their slashes. The additional injury is enough that Fluff-Bunny surrenders.

Departures of a military kind

Uther Xavier-Beaugard has requested the resignation of the Inspector-General of Cavalry. He calls in a favour to help this request; it’s not much of a favour and signally fails to do the job.

Les Petites Bêtes Soyeuses

Being a postal game of *En Garde!* run by Pevans since April 1986 and now published as part of *To Win Just Once*.

New players are always welcome. If you'd like to play, you'll need to subscribe to *TWJO* (see the back page). You will also need a copy of the published rules to *En Garde!* (see www.engarde.co.uk).

Orders for May 1667 to Pevans at 180 Aylsham Drive, UXBRIDGE UB10 8UF, UK or lpbsorders@pevans.co.uk by Friday 14th November 2014



April 1667 (278)

There are no Parisians fighting duels this month.

April fool! Of course there are Parisians fighting duels. First up are Arsène Est, the sabre-wielding Cardinal's Guard, and Xavier Self Zeffort, a man with a foil. Or not. Neither of them shows up for their appointment, so it's not much of an appointment really, and certainly no kind of duel.

Frele d'Acier has a doctor's note letting him off duelling this month. So Terence Cuckpowder chooses Yves Vrai Bretheauteque as the first Dragoon Guard he crosses swords with. Cuckpowder isn't that big a guy, but he'd easily make two of Bretheauteque. It's sabres all round, but Cuckpowder is significantly more proficient with his, giving him all the advantages. The only thing supporting Bretheauteque is his second, Etienne Brule. Rob d'Masses performs the same service for Cuckpowder.

Both men try to claim first blood by opening with a furious lunge. The blunt tips of the sabres do little damage in the initial lunge, but the two men wheel round in perfect synchronisation to cut. Cuckpowder staggers back from the impact of Bretheauteque's blow, but the effect of his cut is more noticeable: it takes Bretheauteque's head off. Literally. Taken by surprise, Brule and Masses hop out of the way. RIP Yves Vrai Bretheauteque.

Now it's Etienne Brule who has to face Cuckpowder's sabre. As far as their build goes, the adversaries are much of a muchness. Cuckpowder's fresh injuries are matched by Brule's older wounds, so their relative expertise may be the deciding

Online Games

TWJO readers are playing online versions of board games – and any reader is welcome to join in. Look for games named “TWJO” something – they have the password “pevans56”. Boîte à Jeux and Yucata don't have a password system, so e-mail me to be invited into a game (or set one up yourself and invite people). My ID is usually Pevans (exceptions noted below). Let me know what other games you fancy playing.

Agricola

Online at www.boiteajeux.net – I'm Pevans56 here and looking for players.

Brass

Online at brass.orderofthehammer.com. Game 12 finished in the middle of September with a win for Pevans on 193 points from Steve Jones on 180. We lost John Boocock in the middle of the game, which was completed by 'StephenV' – thanks for picking up the slack. Game 13 is already complete. Steve won this one, beating Pevans on the tie-breaker as both were on 190 points! Third man was Mike on 163 points. Game 14 is under way.

Nauticus

Online at yucata.de – a recent addition to the site and a game I commented on in *TWJO* 145. Who fancies a go?

Puerto Rico

Online at pr-game.com – it's a classic! Game 9 went to Mark Cowper on 49 points from John Boocock on 46, Pevans on 46 and new recruit Andrew Burgess on 33. Game 10 has already started (though it's titled “game 1” as the website doesn't allow enough characters for the game title!) and Game 11 is waiting for players.

Roll Through the Ages

Online at yucata.de – a game I enjoy, despite being rubbish at it (though I did manage second place in my last game). Who'd like a turn at drubbing me?

Through the Ages

Online at boardgaming-online.com where I'm Paul “Pevans” Evans. Game 8 is waiting for players.

Vinci

Online at yucata.de – another classic, in a version adapted for online play. It's great fun: I just need some opponents, mainly because I keep winning...

Games from Pevans

Mail order board and card games in the UK



Ca\$h'n Guns (2nd ed)

A bonkers game of waving foam rubber guns about as gangsters squabble over dividing the loot. The bullets don't always fly, so there's an element of bluff involved, too. It's great fun and good to have this second edition.

For 4-8 players, aged 10+, playing time 30 minutes: **£23.00**

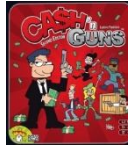

Concordia

This game centres on players' cards, which they use to expand their position on the board, boost their score and collect the things they will score for. The different uses of the cards give players something to think about. It's another cracking game from Mac Gerdts.

For 2-5 players, aged 10+, playing time 100 minutes: ~~£48.00~~
special offer £38.00



Cosmic Encounter (FFG ed)

Fabulously-produced new edition of a classic. The aim is to plant colonies in the other players' star systems, but the key to the game is using your cards and special powers effectively. Winning needs planning, guile and a smidgeon of luck.

For 3-5 players, aged 12+, 1-2 hours to play: **£45.00**

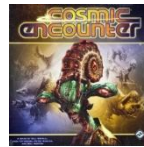

Firefly: the Game

This highly atmospheric science fiction game does an excellent job of reproducing the spirit of the original TV show. Players run their own spaceship from planet to planet, picking up work where they can and dodging the authorities (and the really bad guys!).

For 1-4 players, aged 13+, 2-4 hours to play: **£40.00**



Fortune and Glory

This is a monster of a game themed around 1930s pulp fiction – heroes pursuing 'vile organisations' to save the world – and can be played competitively or co-operatively. It's a game that's worth playing just for experience.

For 1-8 players, aged 12+, playing time 90 minutes: **£70.00**



Mascarade

I tried *Mascarade* without any great expectations and was crying with laughter within a few minutes. This is the funniest game I've played for quite a while. And it's so simple. Each player has a character card in front of them. However, even they don't necessarily know which character! When they claim an action, others may challenge... It's great fun, especially after a couple of beers!

For 2-13, aged 10+, playing time 30 minutes: **£16.00**



Memoir '44: D-Day Landings

Released for the 10th anniversary of *Memoir '44* (and the 70th of D-Day), this is a folder of giant cardstock boards pre-printed for a selection of D-Day scenarios. All five landing beaches are included, along with the American Airborne landings (to the west of the beaches). The scenarios allow all or a section of each board to be played with one or multiple players on each side.

Expansion for *Memoir '44* (2 players, aged 8+): **£27.00**



Start Player

"Choose a player to start" is the instruction in many games. But how? *Start Player* is the answer. Shuffle the deck, draw a card and identify the start player: the tallest person, whoever has the most open buttons, the player with the longest hair... This is such a simple and utterly brilliant idea and an accessory no gamer should be without.

For any number of players, of any age, playing time 30 seconds: **£12.00**



Expansions

Commands & Colors: Napoleonic – The Austrian Army

Pieces for the Austrian Empire's multi-national army plus scenarios for its battles with Napoleon's France in 1805 and 1809, culminating in the Battle of Wagram.

For 2 players, aged 12+, playing time 90 minutes: **£40.00**

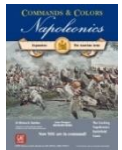

Firefly: the Game – Pirates and Bounty Hunters

This expansion adds new types of spaceship, allows more players to take part and gives players opportunities to play pirate and to claim bounties on the 'verse's Most Wanted.

For 2-6 players, aged 13+, playing time 2-4 hours: **£25.00**



Online at www.pevans.co.uk/Games